



G3 Max Automatic Lubrication Pump

332305H

EN

For dispensing of NLGI Grades #000 to #2 greases and oil with at least 40cSt. For Professional Use Only.

Not approved for use in explosive atmospheres or hazardous locations.

Part Nos., page 3

5100 psi (35.1 MPa, 351.6 bar) Pump Output Pressure

5000 psi (34.4 MPa, 344.7 bar) Maximum Working Pressure - Auto-Fill Shut Off



Important Safety Instructions

Read all warnings and instructions in this manual. Save all instructions.

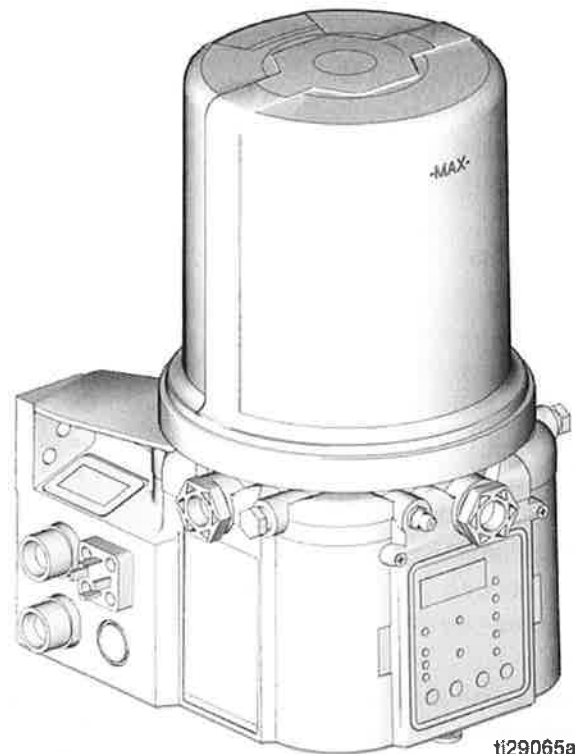

ti29065a



Conforms to ANSI/UL 73
Certified to CAN/CSA
Std. 22.2 No 68-09



Contents

Part / Model Numbers	3	Troubleshooting	71
2 Liter Models	3	Maintenance	73
4 Liter Models	3	Parts - 2 Liter Models	74
8 Liter Models	4	Parts - 4 Liter and Larger Models	75
12 Liter Models	4	Parts	76
16 Liter Models	4	Technical Data	79
Understanding the Model Number	5	Dimensions	80
Warnings	6	Mounting Pattern	81
Installation	8	Graco Standard Warranty	82
Unpacking	8	Graco Information	82
Component Identification	9		
Typical Installation	10		
Typical Installation -			
With Remote Fill Manifold	11		
Optional Installation -			
Without Remote Fill Manifold	12		
System Configuration and Wiring	13		
Setup	21		
Connecting to Auxiliary Fittings	21		
Setting Pump Outlet Volume	22		
Loading Grease	22		
Auto-Fill Shut Off	24		
Filling Oil Unit	26		
Priming	27		
Quick Setup Guide	28		
Max Model Setup	29		
Control Panel Overview	29		
Programming the Max Model	30		
PUMP OFF / REST Setup	35		
DMS™ Models Only	38		
Storing Pump Program Settings			
to the Flash Drive	38		
Uploading Pump Program Settings to the Pump			
39			
Operation / Data Log	40		
System Event Log	40		
Error Log	41		
Functional Summary	43		
Technical Summary	45		
Advanced Programming	46		
Run Mode	54		
Time Control	54		
Alarms: Firmware Versions 6.01 and Below	59		
Fault / Warning Scenarios	59		
Alarms: Firmware Versions 6.02 and Above	65		
Fault / Warning Scenarios	65		

Part / Model Numbers

The Part Number is a six-digit unique number that is only used to order the G3 Pump. Directly related to this six digit Part Number is the configured Graco Model Number. This configured number identifies the distinct features of a specific G3 Pump. To help you understand each component that makes up the Model Number see Understanding Your Model Number, page 5. The tables below shows the relationship between each Part Number and its related Model Number.

2 Liter Models

Part	Model Numbers
96G017	G3-G-24MX-2L0L00-10CV00R0
96G018	G3-G-24MX-2LFL00-10CV00R0
96G019	G3-G-ACMX-2L0L00-1D0V0000
96G020	G3-G-ACMX-2LFL00-1D0V0000
96G021	G3-G-12MX-2L0L00-1DMVA2R3
96G023	G3-G-24MX-2L0L00-1DMVA2R3
96G024	G3-G-24MX-2LFL00-1DMVA2R3
96G025	G3-G-ACMX-2L0L00-1DMVA2R3
96G026	G3-G-ACMX-2LFL00-1DMVA2R3
96G030	G3-G-12MX-2L0L00-10C00000
96G031	G3-G-24MX-2L0L00-10C000R0
96G032	G3-G-ACMX-2L0L00-1D000000
96G035	G3-G-12MX-2L0L05-10CV0000
96G036	G3-G-24MX-2L0L05-10CV0000
96G037	G3-G-ACMX-2L0L00-1D00A000
96G098	G3-G-12MX-2L0L00-UDMVA1R2
96G107	G3-A-24MX-2L0L00-1DMVA2R3
96G110	G3-G-24MX-2L0L00-UDMVA1R2
96G115	G3-G-24MX-2LFL00-UDMVA1R2
96G122	G3-A-ACMX-2L0L00-1DMVA2R3
96G125	G3-G-ACMX-2L0L00-UDMVA1R2
96G132	G3-G-ACMX-2LFL00-UDMVA1R2
96G174	G3-A-ACMX-2L0L00-UDMVA1R2
96G178	G3-G-24MX-2L0L00-0D00A100
96G190	G3-A-24MX-2L0L00-UDMVA1R2
96G206	G3-G-24MX-24L0L07-0D00A000

4 Liter Models

Part	Model Numbers
96G088	G3-G-24MX-4L0L00-10CV00R0
96G090	G3-G-24MX-4LFL00-10CV00R0
96G092	G3-G-ACMX-4L0L00-1D0V0000
96G094	G3-G-ACMX-4LFL00-1D0V0000
96G096	G3-G-12MX-4L0L00-1DMVA2R3
96G099	G3-G-12MX-4L0L00-UDMVA1R2
96G103	G3-G-24MX-4L0L00-1DMVA2R3
96G108	G3-A-24MX-4L0L00-1DMVA2R3
96G111	G3-G-24MX-4L0L00-UDMVA1R2
96G113	G3-G-24MX-4LFL00-1DMVA2R3
96G116	G3-G-24MX-4LFL00-UDMVA1R2
96G118	G3-G-ACMX-4L0L00-1DMVA2R3
96G123	G3-A-ACMX-4L0L00-1DMVA2R3
96G126	G3-G-ACMX-4L0L00-UDMVA1R2
96G128	G3-G-ACMX-4LFL00-1DMVA2R3
96G133	G3-G-ACMX-4LFL00-UDMVA1R2
96G141	G3-G-12MX-4L0L00-10C00000
96G143	G3-G-24MX-4L0L00-10C00000
96G145	G3-G-ACMX-4L0L00-1D000000
96G151	G3-G-12MX-4L0L05-10CV0000
96G153	G3-G-12MX-4L0L05-U0CV0100
96G155	G3-G-24MX-4L0L05-10CV0000
96G157	G3-G-24MX-4L0L05-U0CV0100
96G159	G3-G-12MX-4L0L05-00C0010M
96G160	G3-G-24MX-4L0L05-00C0010M
96G161	G3-G-12MX-4L0L05-U0C0010M
96G162	G3-G-24MX-4L0L05-U0C0010M
96G175	G3-A-ACMX-4L0L00-UDMVA1R2
96G181	G3-G-24MX-4L0L03-00C00100
96G183	G3-G-ACMX-4L0L00-1D00A000
96G188	G3-A-24MX-4L0L05-U0C0010M
96G212	G3-G-24MX-4LAL05-10CV0000
96G218	G3-G-12MX-4LFL00-10MVA2R3
96G232	G3-6-12MX-4L0005-10CV0000

8 Liter Models

Part	Model Numbers
96G089	G3-G-24MX-8L0L00-10CV00R0
96G093	G3-G-ACMX-8L0L00-1D0V0000
96G097	G3-G-12MX-8L0L00-1DMVA2R3
96G100	G3-G-12MX-8L0L00-UDMVA1R2
96G104	G3-G-24MX-8L0L00-1DMVA2R3
96G109	G3-A-24MX-8L0L00-1DMVA2R3
96G112	G3-G-24MX-8L0L00-UDMVA1R2
96G119	G3-G-ACMX-8L0L00-1DMVA2R3
96G124	G3-A-ACMX-8L0L00-1DMVA2R3
96G127	G3-G-ACMX-8L0L00-UDMVA1R2
96G142	G3-G-12MX-8L0L00-10C00000
96G144	G3-G-24MX-8L0L00-10C00000
96G146	G3-G-ACMX-8L0L00-1D000000
96G152	G3-G-12MX-8L0L05-10CV0000
96G154	G3-G-12MX-8L0L05-U0CV0100
96G156	G3-G-24MX-8L0L05-10CV0000
96G158	G3-G-24MX-8L0L05-U0CV0100
96G176	G3-A-ACMX-8L0L00-UDMVA1R2
96G177	G3-G-24MX-8L0L05-00C0010M
96G186	G3-A-12MX-8L0L05-U0C0010M
96G191	G3-G-24MX-8L0L05-10CV02M3
96G195	G3-A-24MX-8L0L05-U0C0010M
96G197	G3-G-ACMX-8LFL00-1DMVA2R3
96G209	G3-G-ACMX-8LAL00-1DV00000
96G215	G3-G-24MX-8LAL05-10CV0000
96G216	G3-G-24MX-8L0L08-10CV00000

12 Liter Models



Part	Model Numbers
96G105	G3-G-24MX-120L00-1DMVA2R3
96G120	G3-G-ACMX-120L00-1DMVA2R3
96G164	G3-G-24MX-120L05-10CV00000
96G165	G3-G-24MX-120L05-U0CV0100
96G231	G3-A-12MX-120L08-V0C0010M











16 Liter Models

Part	Model Numbers
96G106	G3-G-24MX-160L00-1DMVA2R3
96G121	G3-G-ACMX-160L00-1DMVA2R3
96G166	G3-G-ACMX-160L00-1D0V0000
96G168	G3-G-24MX-160L05-10CV0000
96G169	G3-G-24MX-160L05-U0CV0100
96G185	G3-G-24MX-160L05-U0C0010M
96G201	G3-A-ACMX-160L00-UDMVA1R2
96G219	G3-G-24MX-160L08-10CV0000

Warnings

The following warnings are for the setup, use, grounding, maintenance, and repair of this equipment. The exclamation point symbol alerts you to a general warning and the hazard symbols refer to procedure-specific risks. When these symbols appear in the body of this manual or on warning labels, refer back to these Warnings. Product-specific hazard symbols and warnings not covered in this section may appear throughout the body of this manual where applicable.

 WARNING	
	<p>ELECTRIC SHOCK HAZARD</p> <p>This equipment must be grounded. Improper grounding, setup, or usage of the system can cause electric shock.</p> <ul style="list-style-type: none"> • Turn off and disconnect power at main switch before disconnecting any cables and before servicing or installing equipment. • Connect only to grounded power source. • All electrical wiring must be done by a qualified electrician and comply with all local codes and regulations.
	<p>EQUIPMENT MISUSE HAZARD</p> <p>Misuse can cause death or serious injury.</p> <ul style="list-style-type: none"> • Do not operate the unit when fatigued or under the influence of drugs or alcohol. • Do not exceed the maximum working pressure or temperature rating of the lowest rated system component. See Technical Data in all equipment manuals. • Use fluids and solvents that are compatible with equipment wetted parts. See Technical Data in all equipment manuals. Read fluid and solvent manufacturer's warnings. For complete information about your material, request MSDS from distributor or retailer. • Turn off all equipment and follow the Pressure Relief Procedure when equipment is not in use. • Check equipment daily. Repair or replace worn or damaged parts immediately with genuine manufacturer's replacement parts only. • Do not alter or modify equipment. Alterations or modifications may void agency approvals and create safety hazards. • Make sure all equipment is rated and approved for the environment in which you are using it. • Use equipment only for its intended purpose. Call your distributor for information. • Route hoses and cables away from traffic areas, sharp edges, moving parts, and hot surfaces. • Do not kink or over bend hoses or use hoses to pull equipment. • Keep children and animals away from work area. • Comply with all applicable safety regulations.

 WARNING	
  	<p>SKIN INJECTION HAZARD</p> <p>High-pressure fluid from dispensing device, hose leaks, or ruptured components will pierce skin. This may look like just a cut, but it is a serious injury that can result in amputation. Get immediate surgical treatment.</p> <ul style="list-style-type: none"> • Do not point dispensing device at anyone or at any part of the body. • Do not put your hand over the fluid outlet. • Do not stop or deflect leaks with your hand, body, glove, or rag. • Follow the Pressure Relief Procedure when you stop dispensing and before cleaning, checking, or servicing equipment. • Tighten all fluid connections before operating the equipment. • Check hoses and couplings daily. Replace worn or damaged parts immediately.
 	<p>PRESSURIZED EQUIPMENT HAZARD</p> <p>Over-pressurization can result in equipment rupture and serious injury.</p> <ul style="list-style-type: none"> • A pressure relief valve is required at each pump outlet. • Follow Pressure Relief Procedure in this manual before servicing.
	<p>PLASTIC PARTS CLEANING SOLVENT HAZARD</p> <p>Many solvents can degrade plastic parts and cause them to fail, which could cause serious injury or property damage.</p> <ul style="list-style-type: none"> • Use only compatible water-based solvents to clean plastic structural or pressure-containing parts. • See Technical Data in this and all other equipment instruction manuals. Read fluid and solvent manufacturer's SDSs and recommendations.
 	<p>MOVING PARTS HAZARD</p> <p>Moving parts can pinch, cut or amputate fingers and other body parts.</p> <ul style="list-style-type: none"> • Keep clear of moving parts. • Do not operate equipment with protective guards or covers removed. • Pressurized equipment can start without warning. Before checking, moving, or servicing equipment, follow the Pressure Relief Procedure and disconnect all power sources.
	<p>PERSONAL PROTECTIVE EQUIPMENT</p> <p>Wear appropriate protective equipment when in the work area to help prevent serious injury, including eye injury, hearing loss, inhalation of toxic fumes, and burns. This protective equipment includes but is not limited to:</p> <ul style="list-style-type: none"> • Protective eye wear, and hearing protection. • Respirators, protective clothing, and gloves as recommended by the fluid and solvent manufacturer

Installation

Unpacking

NOTICE
Observe precautions for handling electrostatic sensitive devices. Touch ground before handling pump.

The pump module was carefully packaged for shipment by Graco. When the package arrives, perform the following procedure to unpack the units:

1. Inspect the shipping box carefully for shipping damage. Contact the carrier promptly if damage is discovered.
2. Unseal the box and inspect the contents carefully. There should not be any damaged parts.
3. Compare the packing slip against all items included in the box. Any shortages or other inspection problems should be reported immediately.

Choosing an Installation Location



AUTOMATIC SYSTEM ACTIVATION HAZARD

If the system is equipped with has an automatic timer (user supplied) that activates the pump lubrication system when power is connected or when exiting the programming function, unexpected activation of the system could result in serious injury, including skin injection and amputation.

Before you install or remove the lubrication pump from the system, disconnect and isolate all power supplies and relieve all pressure.

- Select a location that will adequately support the weight of the G3 Pump and lubricant, as well as all plumbing and electrical connections.
- Refer to the mounting hole layouts provided in the Mounting Pattern section of this manual, page 81. No other installation configuration should be used.

- Use designated mounting holes and provided configurations only.
- Always mount the G3 oil models upright.
- If the G3 grease model is going to be operated in a tilted or inverted position for any period of time, you must use a model that includes a follower plate, otherwise the G3 must be mounted upright. Refer to your model number to confirm if a follower plate was installed on your pump. See page 5, Understanding the Model Number to identify this character in your model number.
- Use the three fasteners (included) to secure the G3 to the mounting surface.
- Some installations may require an additional reservoir support bracket. See Table below for bracket information.

In high vibration environments and when using an AC model, additional dampening at mounting point is necessary.

Part No	Description
571159	Reservoir bracket and strap
125910	L-Bracket for pump
127665	USP to G-Series mounting bracket

Component Identification

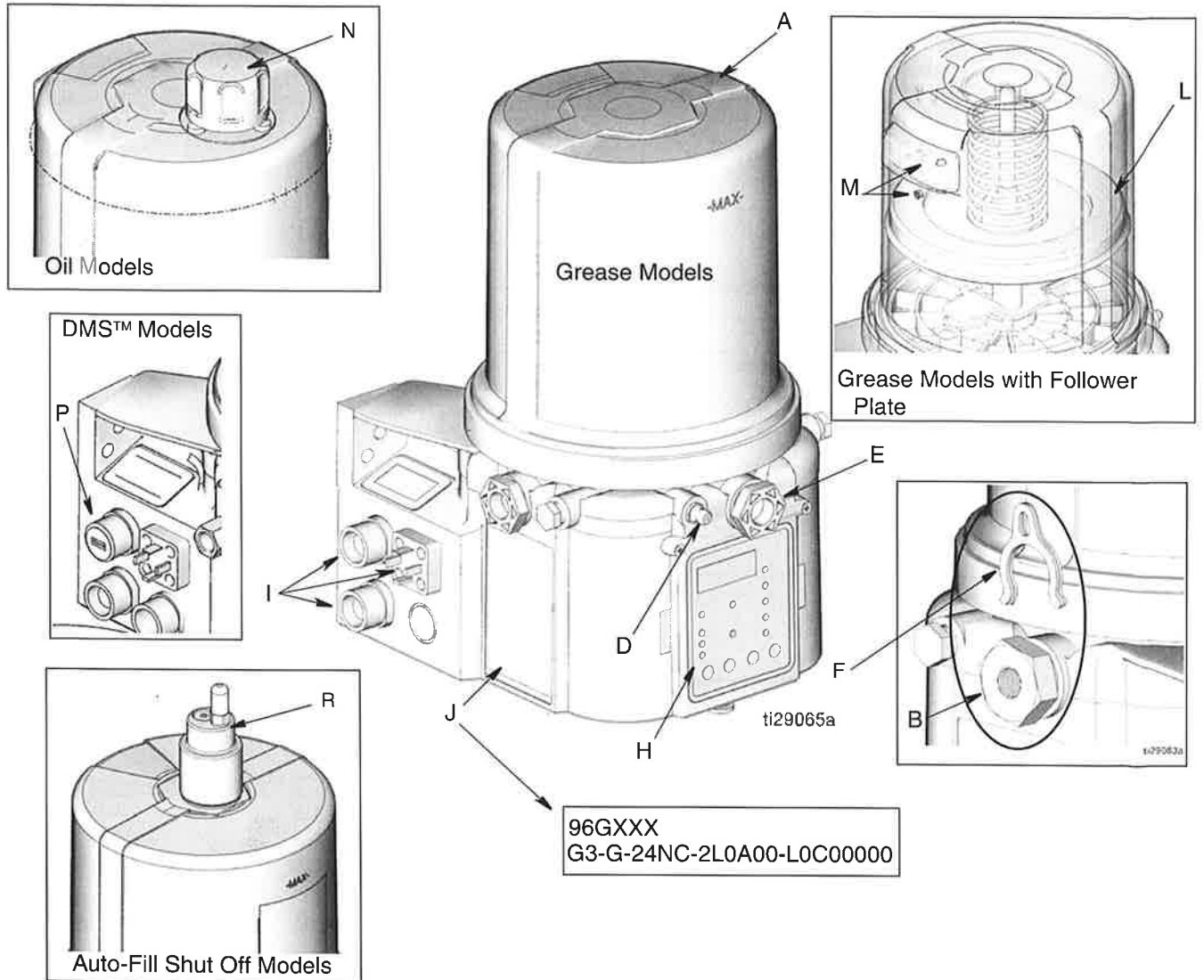

FIG. 2:

Key:

- | | |
|---|--|
| <p>A Reservoir
 B Pump Element (1 included. Can accommodate 3 total)
 C Pressure Relief Valve (Not shown. Not included / required for each outlet - Available from Graco. See Parts, page 77.)
 D Zerk Inlet Fill Fitting (1 included / grease models only)
 E Pump Outlet Plug (2 included)
 F Volume Control Spacers (2 included. More spacers = less output volume per stroke) (also see FIG. 20, page 22)
 G Fuse (DC models only - Not included, not shown. Available from Graco. See Parts, page 78.)
 H Control Panel
 I Power / Sensor Panel (both sides; only one side shown)
 J Part Number / Model Number example only shown, (see pages 5, Understanding the Model Number, for details)
 K Power Cord (not shown)</p> | <p>L Follower Plate (grease models only / not available on all grease models)
 M Vent Hole for Follower Plate (grease models only / not available on all grease models)
 N Fill cap (oil models only)
 P USB Port (DMS™ Models only)
 R Auto-Fill Shut Off</p> |
|---|--|

Typical Installation

Series Progressive Divider Valve Installations

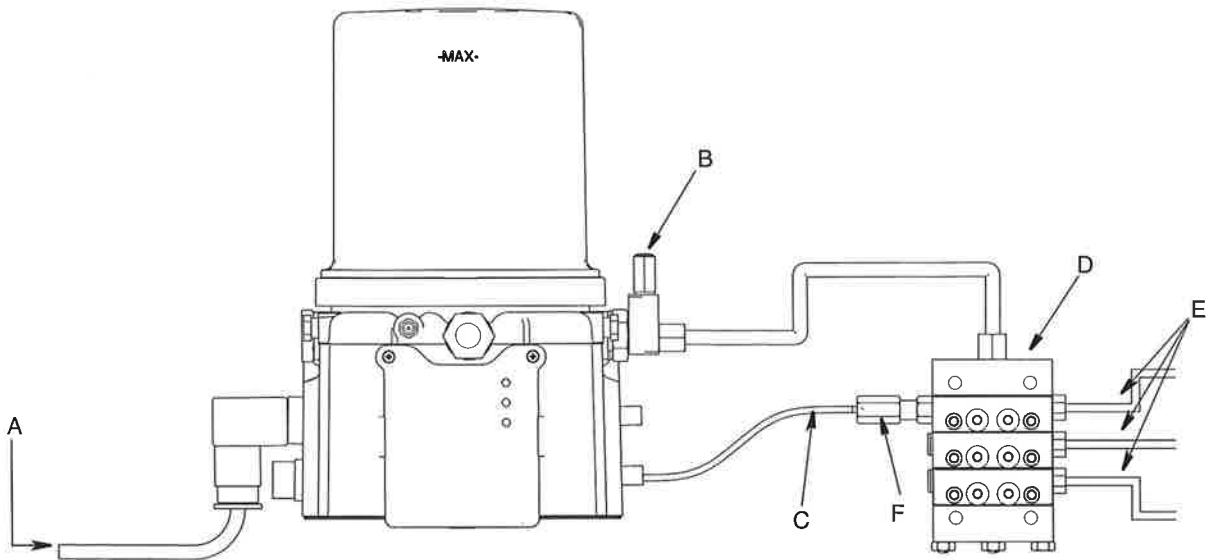

FIG. 3

Injector Installations

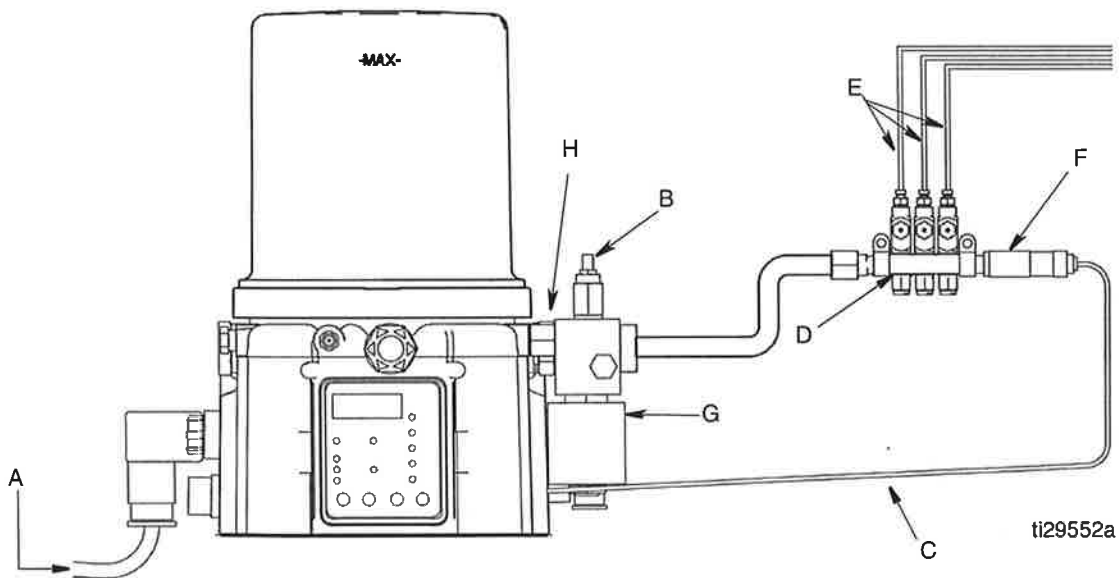

FIG. 4

- | | |
|--|---|
| <p>A Connected to fused power source</p> <p>B Pressure relief valve (Not included/required for each outlet - user supplied. See Parts, page 77)</p> <p>C - Cycle indicator sensor cable (Divider Installations)
- Pressure switch cable (Injector Installations)</p> <p>D - Series progressive divider valves (Divider Installations)
- Injectors (Injector Installations)</p> <p>E To lube points</p> | <p>F - Proximity Switch (Divider Installations)
- Pressure switch (Injector Installations)</p> <p>G Vent valve (Not included / available from Graco. See Parts, beginning on page 76.)</p> <p>H Return to reservoir</p> |
|--|---|

Typical Installation - With Remote Fill Manifold

The installation shown is only a guide for selecting and installing system components. Contact your Graco distributor for assistance in planning a system to suit your needs.

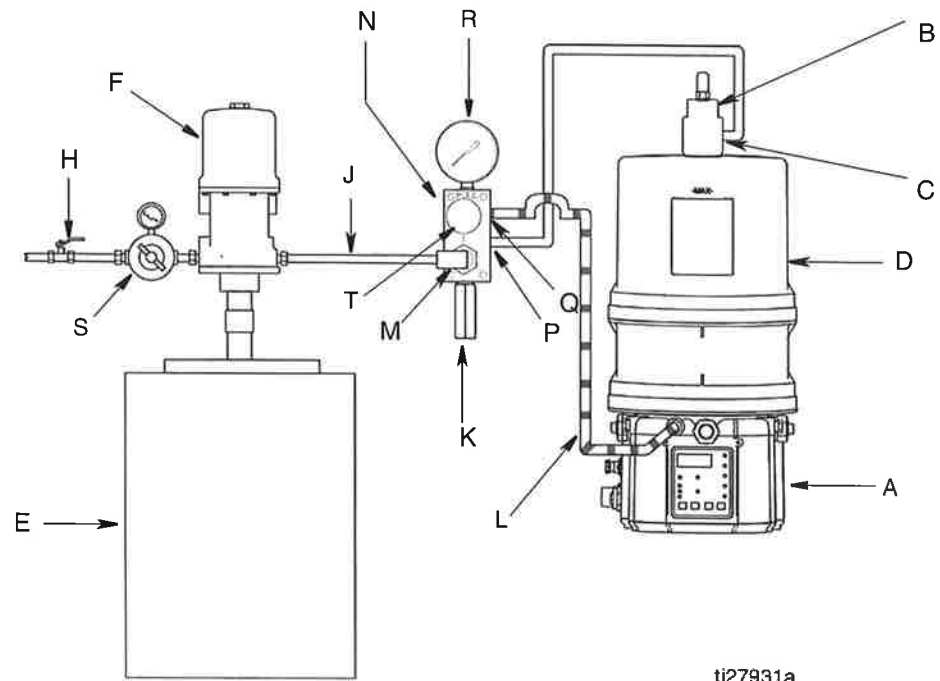

FIG. 5

Key:

- A G3 Pump
- B Auto-Fill Shut Off Valve
- C Auto-Fill Inlet
- D G3 Reservoir
- E Remote Fill Reservoir
- F Remote Fill Pump
- G Supply Hose (user supplied)
- H Air Supply to Refill Pump
- J Supply Hose (user supplied)
- K Pressure Relief Valve
- L Drain Hose
- M Fill Coupler/Inlet (quick disconnect)
- N Fill Manifold❖
- P Fill Manifold Outlet
- Q Fill Manifold Vent Port
- R Pressure Gauge
- S Pressure Regulator and Gauge
- T Pressure Relief Knob

❖ To relieve the stall pressure in the fill line a fill manifold (N) **must** be installed in the system.

Optional Installation - Without Remote Fill Manifold

The installation shown is only a guide for selecting and installing system components. Contact your Graco distributor for assistance in planning a system to suit your needs.

NOTE: The remote filling station pump stalls (dead-heads) when the reservoir is full. If the pump does not stall (dead-head) there is a leak in the system.

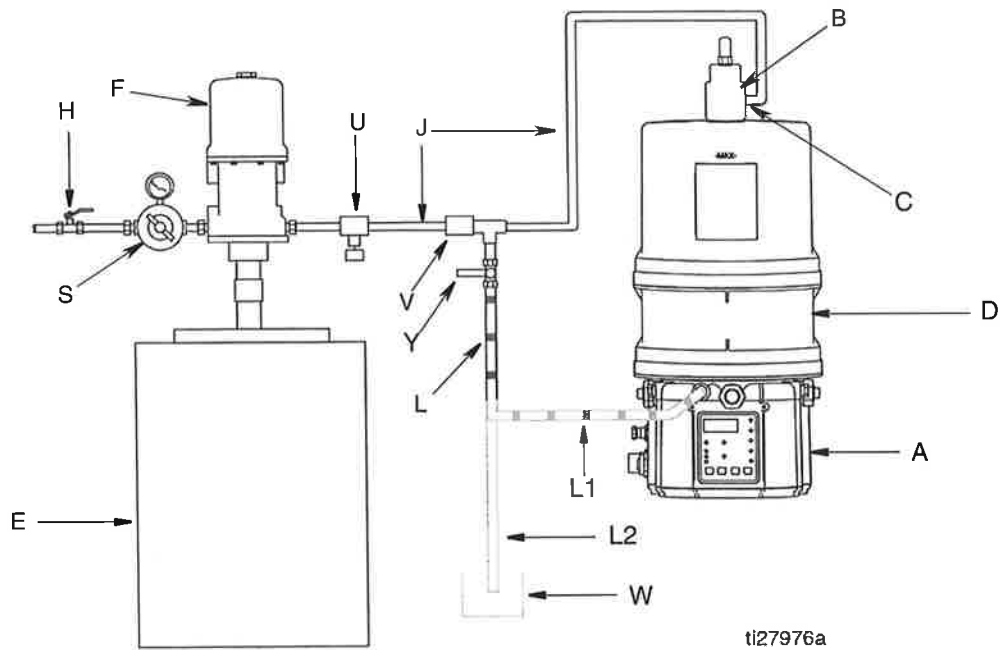

FIG. 6

Key:



- A G3 Pump
- B Auto-Fill Shut Off Valve
- C Auto-Fill Inlet
- D G3 Reservoir
- E Remote Fill Reservoir
- F Remote Fill Pump
- H Relief Valve
- J Supply Hose (user supplied)
- L Drain Tube
- L1 Option - To reservoir
- L2 Option - To overflow container

- S Pressure Regulator and Gauge
- U Pressure Relief Valve
- V Quick Disconnect
- W Overflow Container
- Y Supply Hose Pressure Relief Valve❖

❖ To relieve the stall pressure in the fill line a ball valve (Y) **must** be installed in the system.

System Configuration and Wiring

Grounding

				
---	---	---	--	--

The equipment must be grounded to reduce the risk of static sparking and electric shock. Electric or static sparking can cause fumes to ignite or explode. Improper grounding can cause electric shock. Grounding provides an escape wire for the electric current.

Improper installation of the grounding conductor may result in a risk of electric shock. This product must be installed by a qualified electrician in compliance with all state and local codes and regulations.

If the product is permanently connected:

- it must be installed by a qualified electrician or serviceman.
- it must be connected to a grounded, permanent wiring system.

If an attachment plug is required in the end use application:

- it must be rated for the product electrical specifications.
- it must be an approved, 3-wire grounding type attachment plug.
- it must be plugged into an outlet that is properly installed and grounded in accordance with all local codes and ordinances.
- when repair or replacement of the power cord or plug is required, do not connect the grounding wire to either flat blade terminal.

Fuses

NOTICE
Fuses (user supplied) are required on all DC models. To avoid equipment damage:
<ul style="list-style-type: none"> • Never operate G3 Pump DC models without a fuse installed. • A fuse of the correct voltage must be installed in line with the power entry to the system.

Fuse Kits are available from Graco. The following Table identifies the correct fuse to use for your input voltage and the corresponding Graco Kit number.

Input Voltage	Fuse Value	Graco Kit No.
12 VDC	7.5 A	571039
24 VDC	4 A	571040

Recommendations for Using Pump in Harsh Environments

- Use pump with CPC style power cable.
- If using a DIN style power or alarm harness with a right angle mating connector, make sure the connector does not exit the unit in the UP direction.
- Use a corrosion preventative electrical grease on all contacts.

Alarm Output and Remote Illumination Response

The following tables include graphical representations of the connector as it appears on the unit, a pin-out associated with the connector and a typical installation wiring diagram. An internal representative wiring diagram is included where it is deemed useful.

Wire colors provided on these pages only refer to the power cable provided by Graco with this product.





	Alarm Output (via DIN alarm relay connector)	Standard Remote Illumination (via 5 wire CPC power cable)	Tri-Color Remote Illumination (via M12 Connector)
Unit in OFF Mode	Deactivated (off)	Off	Off
Unit in ON Mode	Deactivated (off)	On	Green
Warning Condition (A11 OFF)	Activated (on)	Toggles On and Off once per second	Yellow
Low Level Indication (A9 OFF)	See Warning or Fault Condition	Toggles On and Off once per second	See Warning or Fault Condition
Fault Condition (Advanced Programming A7 OFF)	Toggles On and Off once per second	Toggles On and Off once per second	Red
Fault Condition (Advanced Programming A7 ON)	Activated (on)	Toggles On and Off once per second	Red

Outputs (“08” option) (via 5 wire CPC)

	Pin 4 Alarm	Pin 7 Low Level
Low Level Warning FIRMWARE 6.02 and above (A7 OFF, A9 ON)	Off*	Toggles On and Off once per second
Low Level Warning (A7 OFF, A9 OFF)	Off*	Activated (On)
Low Level Fault (A7 OFF, A9 OFF)	Toggles On and Off once per second	Activated (On)
Low Level Fault (A7 ON, A9 OFF)	Activated (On)	Activated (On)



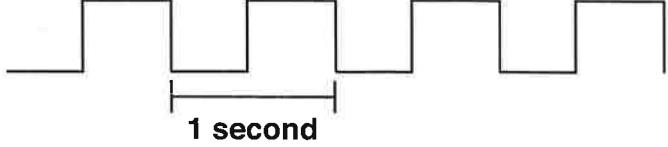

*Firmware 6.04 and above for non-DMS models and 7.07 and above for DMS models. For A11 OFF the Alarm Pin 4 activates ON during a warning. It is shown with A11 ON.

Alarm Relay Response

	Output Tied to Common	
No Faults or Warnings	N.O.	N.C. 
Warning (Advanced Programming Setting A11 OFF)	N.O.	N.C. 
Fault (Advanced Programming A7 OFF)	N.O.	N.C. 
Fault (Advanced Programming Setting A7 ON)	N.O.	N.C. 

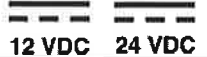
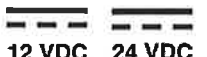
Wiring and Installation Diagrams

The following Table identifies the wiring and installation diagrams provided in this manual.

Diagram	Symbol	Page #
Power DIN AC		16
Power DIN DC		16
Power CPC DC		17
Inputs (M12)		18
Vent Valve Outputs		19
Alarm Outputs		19
Illuminated Manual Run Input		Kits: 571030, 571031, 571032, 571033



Power DIN AC - 15 foot: Part No. 16U790

Pin and Related Wire Color (FIG. 7)

Pin	Pin Name	Color
1	Line	Black
2	Neutral	White
3	Not Used	Not Used
	Ground	Green

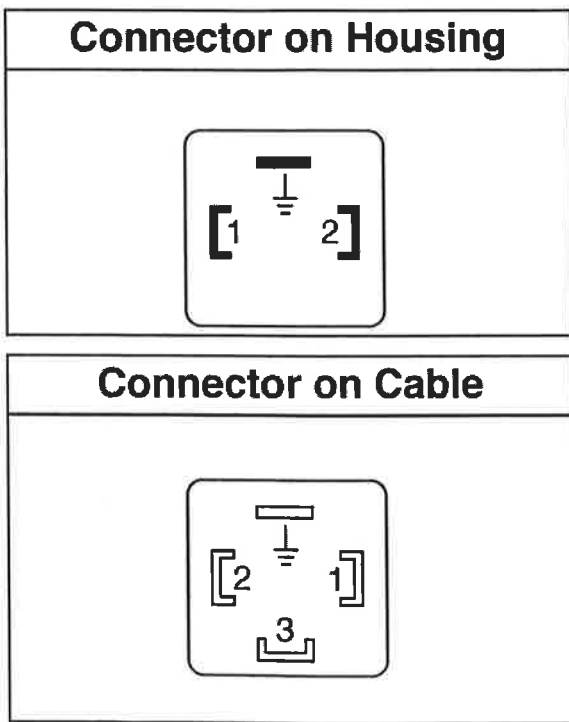



FIG. 7

ti27630a

12 VDC 24 VDC Power DIN DC - 15 foot

Pin and Related Wire Color (FIG. 8)

Pin	Pin Name	Color
1	-VDC	Black
2	+VDC	White
3	Not Used	Not Used
	Not Used	Green

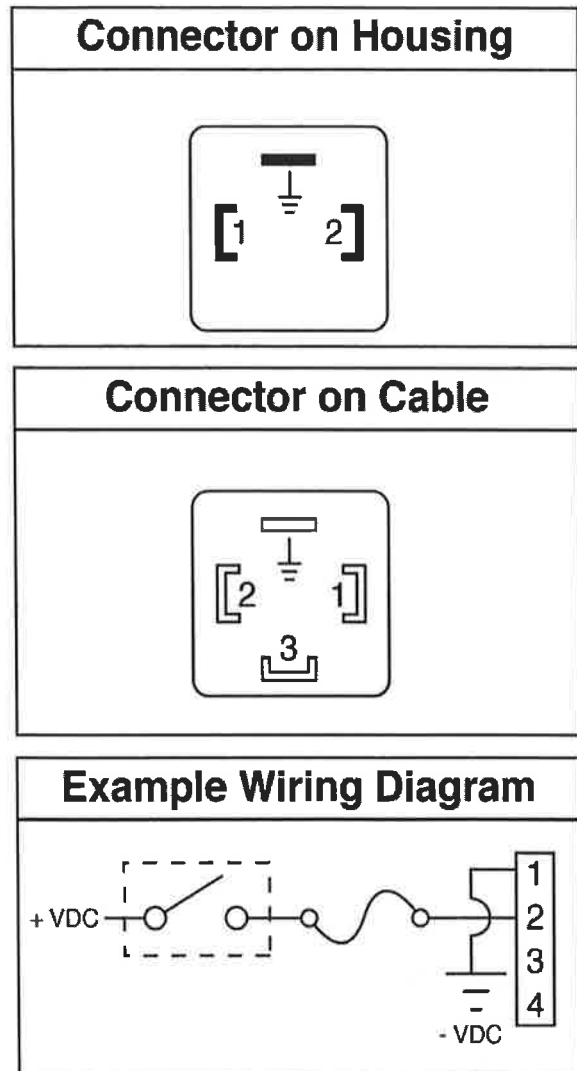

FIG. 8

ti27631a

12 VDC 24 VDC Power CPC DC -15 foot

Pin and Related Wire Color (FIG. 9)

Pin	Pin Name	Color
1	Not Used	Not Used
2	-VDC	Black
3	+VDC	White
4	Not Used	Not Used
5	Not Used	Not Used
6	Not Used	Not Used
7	Not Used	Green

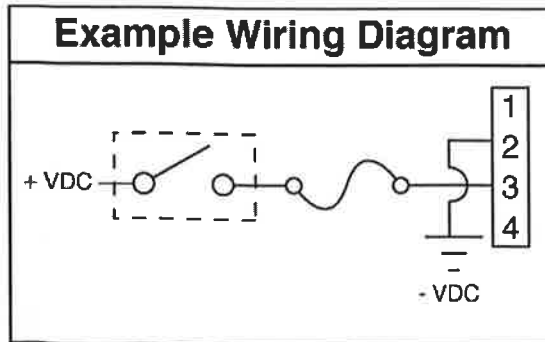
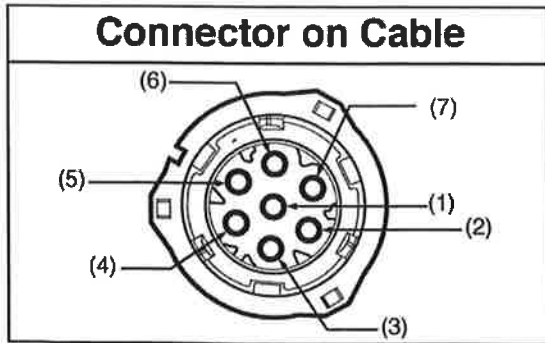
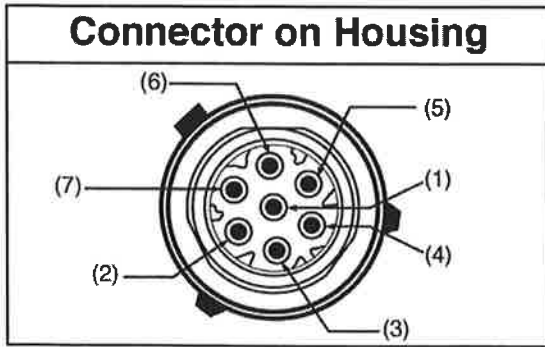

FIG. 9

ti29557a

12 VDC 24 VDC Power CPC DC - 5 Wire

Part No.: 127780: 15 ft (4.5 m)

Part No.: 127781: 20 ft (6.1 m)

Part No.: 127782: 30 ft (9.1 m)

An Illuminated Remote Run Button Kit: 571030, 571031 for starting a manual run cycle if used in conjunction with a 5-wire CPC cable, is available from Graco. Contact your local Graco distributor or Graco Customer Service for additional information about these kits.

Pin and Related Wire Color (FIG. 10)

Pin	Pin Name	Color
1	Not Used	Not Used
2	-VDC	Black
3	+VDC	Red
4	LIGHT	White
5	Manual Run Switch	Orange
6	Not Used	Not Used
7	Not Used	Green

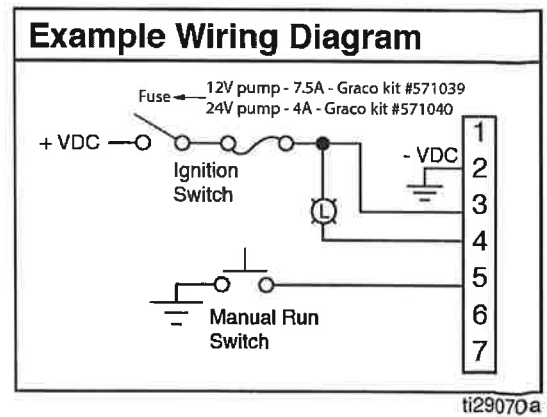
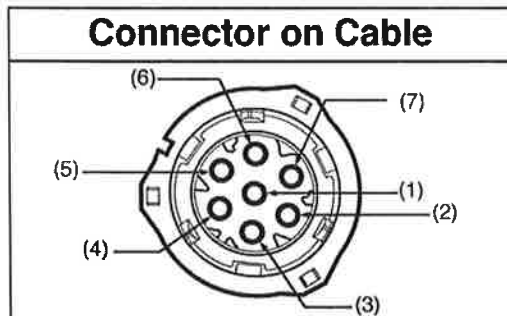
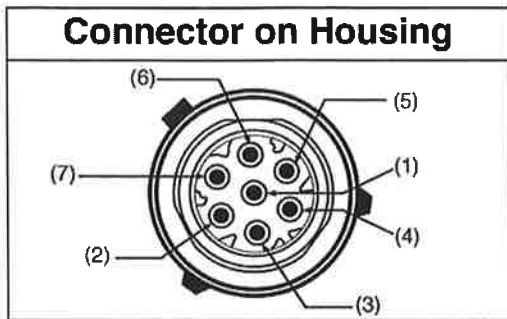

FIG. 10

ti29070a

Pin and Related Wire Color (FIG. 11)
Wiring for "08" Option

CPC Pin	Pin Name	Wire Color
1	Not Used	Not Used
2	-VDC/Com	Black
3	+VDC	Red
4	Alarm	White
5	Manual	Orange
6	Not Used	Not Used
7	Low Level Warning	Green



ii27632a

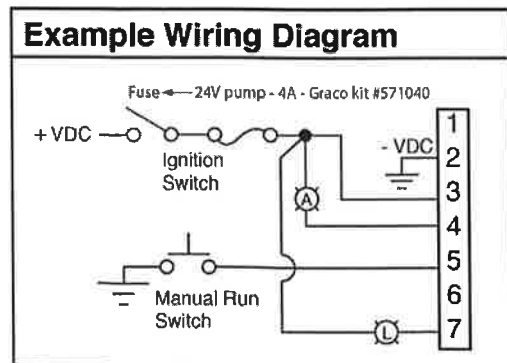

ti29702a

FIG. 11



123

Inputs (M12)

See Technical Data, page 79 for ratings.

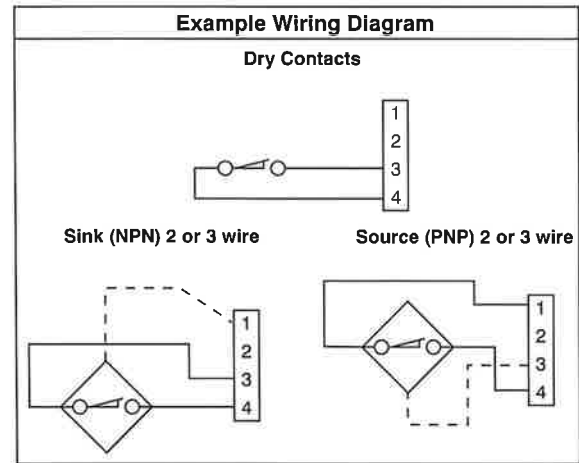
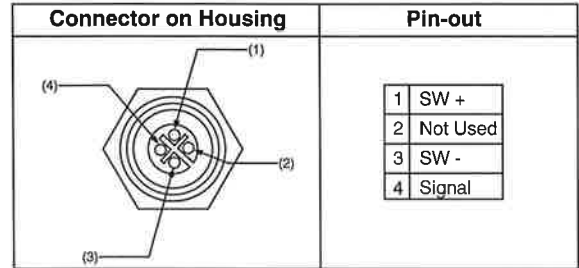
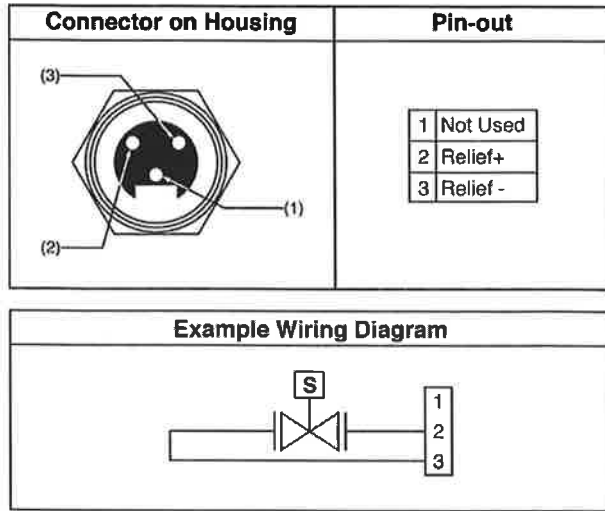

FIG. 12



Vent Valve Outputs

See Technical Data, page 79 for ratings.



ti29555a

FIG. 13



Alarm Outputs

DC example shown. See Technical Data, page 79 for ratings.

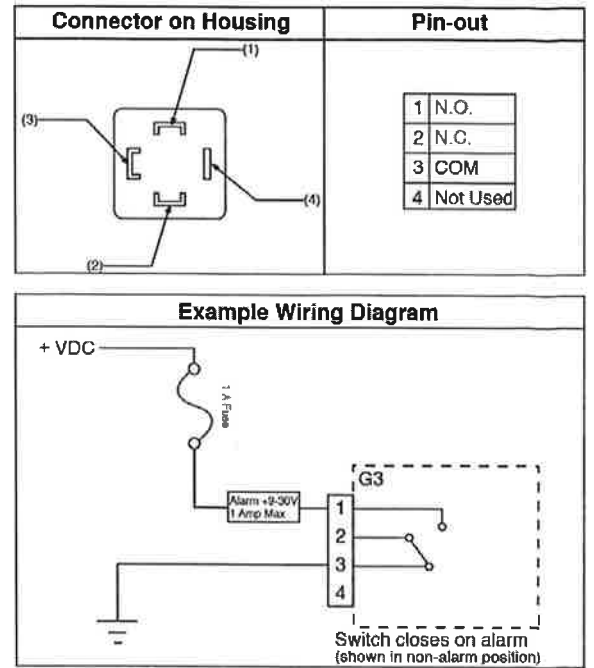

ti29551a

FIG. 14

Part No. 124333: Cable Pin Out (M12)

Wire Colors (FIG. 15)

Item No.	Color
1	Brown
2	White
3	Blue
4	Black

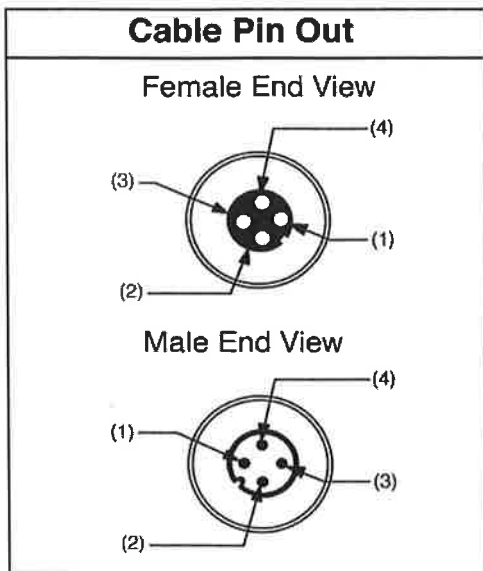

FIG. 15

ti27634a

Part No. 124595: 5 Pin Eurofast Field Wireable Connector

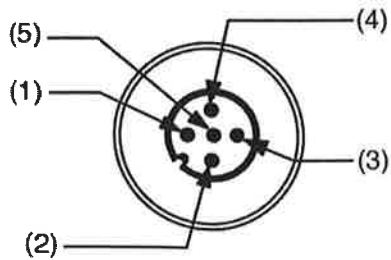

FIG. 16

ti27900a

Part No. 124300: Field Wireable Pin Out (M12)

Wire Colors (FIG. 17)

Item No.	Color
1	Brown
2	White
3	Blue
4	Black

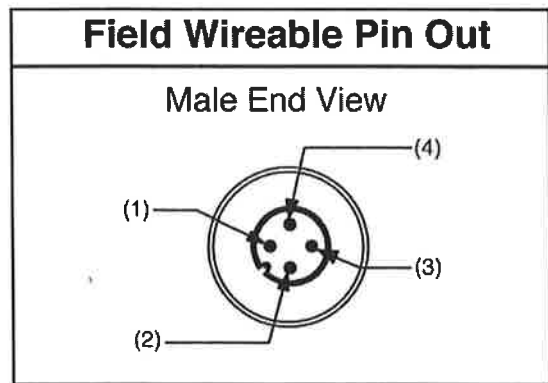

ti27635a

FIG. 17

Part No. 124594: 4 Pin Eurofast Field Wireable Connector

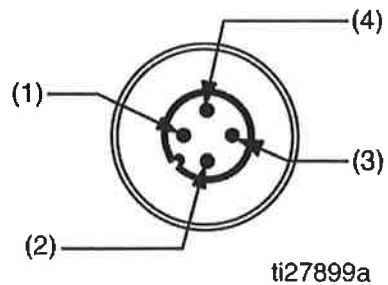

FIG. 18

ti27899a

Setup

Pressure Relief



Follow the Pressure Relief Procedure whenever you see this symbol.



This equipment stays pressurized until pressure is manually relieved. To help prevent serious injury from pressurized fluid, such as skin injection, splashing fluid and moving parts, follow the Pressure Relief Procedure when you stop dispensing and before cleaning, checking, or servicing the equipment.

Relieve pressure in system using two wrenches working in opposite directions on pump element and pump element fitting to **slowly loosen fitting only** until fitting is loose and no more lubricant or air is leaking from fitting.

NOTE: When loosening pump element fitting, do NOT loosen **pump element**. Loosening pump element will change the output volume.

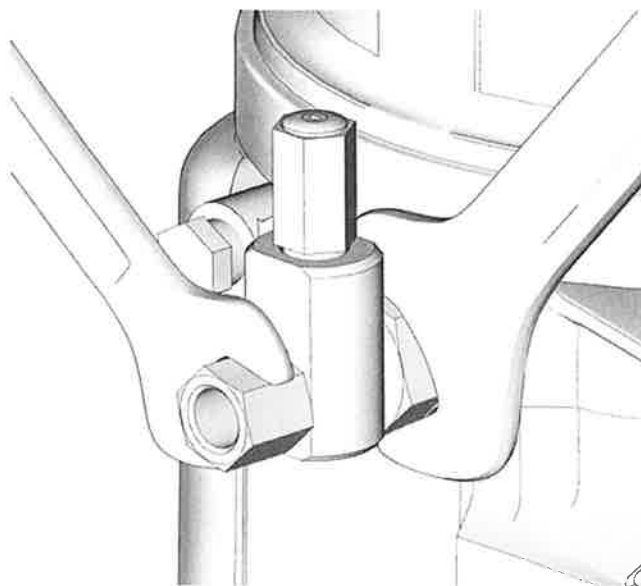
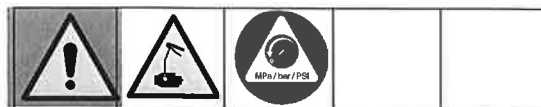

FIG. 19

Connecting to Auxiliary Fittings



NOTICE

Do not attach unsupported equipment to auxiliary fittings such as fill ports and pump element. Attaching unsupported equipment to these fitting can result in irreparable housing damage.

- Always use two wrenches working in opposite directions when connecting anything to pump element or auxiliary fittings. See FIG. 19 for an example.
- Torque pump element fittings to 50 in. lbs (5.6 N•m).
- When connecting pump element into housing torque to 50 in. lbs (5.6 N•m).

Pressure Relief Valves



To prevent over-pressurization, which can result in equipment rupture and serious injury, a pressure relief valve appropriate for the lubrication system must be installed close to every pump outlet to alleviate unintended pressure rises in the system and protect the G3 pump from damage.

- Only use a pressure relief valve that is rated for no more than the working pressure of any component installed in the system. See Technical Data, page 75.
- Install a pressure relief valve close to every pump outlet; before any auxiliary fitting.

NOTE: A pressure relief valve can be purchased from Graco. See Parts, page 77.

Setting Pump Outlet Volume



NOTE:

- Before making any adjustments to pump volume, **Relieve Pressure** following procedure on page 21.
 - Only use Graco supplied spacers to control output volume.
1. Use a wrench to turn pump element counter-clockwise to loosen. Do not remove entire pump element. Only back pump element out enough to allow spacer to be slid on or off.
 2. If needed, remove or insert spacers to achieve required pump output volume. A tool may be needed to facilitate removal.

Pump volume control is set using either no (0) spacers, 1 or 2 spacers (FIG. 20).

Do not use more than 2 spacers to adjust output volume.

No. Spacers	Output Volume / Minute	
	cubic inches	cubic cm
2	0.12	2
1	0.18	3
0	0.25	4

NOTE:

- The amount of dispensed volume can vary depending on external conditions such as lubricant temperature and back pressure from downstream connections.
 - Use of these volume adjustment in conjunction with setting the ON time of the pump will allow for control of the output volume.
 - Use these volume adjustments as a starting point and adjust as necessary to ensure desired lubrication dispense.
3. Tighten pump element fitting. Torque fitting to 50 in. lbs (5.6 N•m).

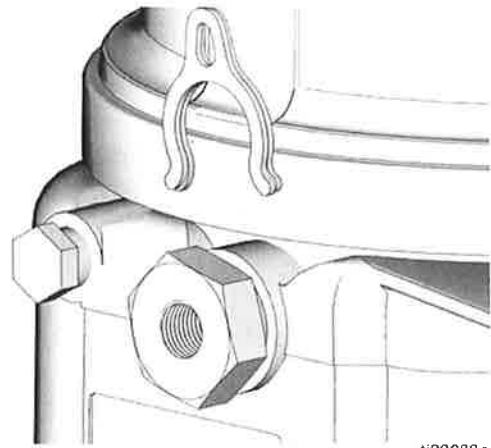

ti29083a

FIG. 20

Loading Grease

To ensure optimal performance from the G3:

- Only use NLGI #000 - #2 greases appropriate for your application, automatic dispensing, and the equipment's operating temperature. Consult with machine and lube manufacturer for details.
- The reservoir can be filled using a hand operated pump, pneumatic pump or electric transfer pump.
- Do not overfill (FIG. 23).
- Do not operate G3 without reservoir attached.

NOTICE

- Always clean inlet fitting (D) (FIG. 21) with a clean dry cloth prior to filling reservoir. Dirt and/or debris can damage pump and/or lubrication system.
- Care must be used when filling the reservoir using a pneumatic or electric transfer pump to not pressurize and break the reservoir.

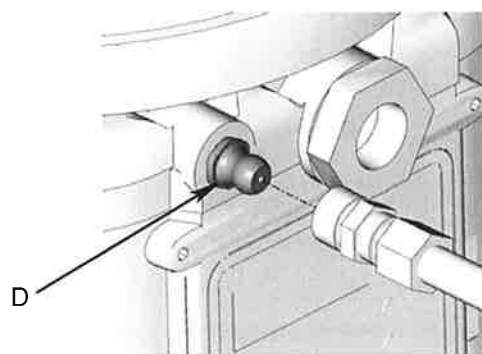

FIG. 21

Models without a follower plate:

1. Connect fill hose to inlet fitting (D) (FIG. 22).

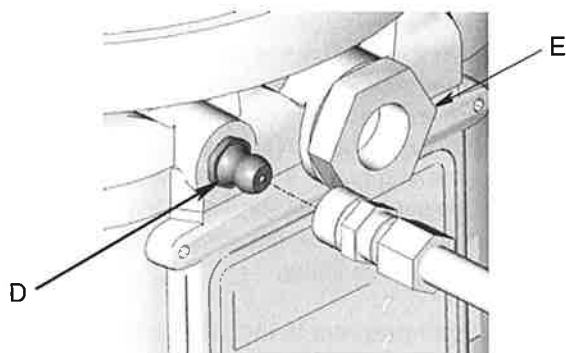

FIG. 22

2. For higher viscosity fluids, start pump to rotate stirring paddle during fill to prevent air pockets from forming in grease.

To start the pump press the manual run button.



3. Fill reservoir with NLGI grease to max fill line.

NOTE: Vent port, located in rear of reservoir, should not be used as an overfill port/indicator.

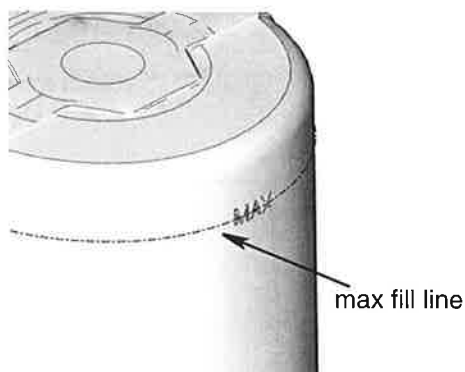

FIG. 23

4. Remove fill hose.

Models with a follower plate:

1. Connect fill hose to inlet fitting (D) (FIG. 22).
2. For higher viscosity fluids, start pump to rotate stirring paddle during fill to prevent air pockets from forming in grease.

To start the pump press the manual run button.



3. Fill reservoir with grease until seal of follower plate breaches the vent hole (FIG. 24) and the majority of air is expelled from the reservoir.

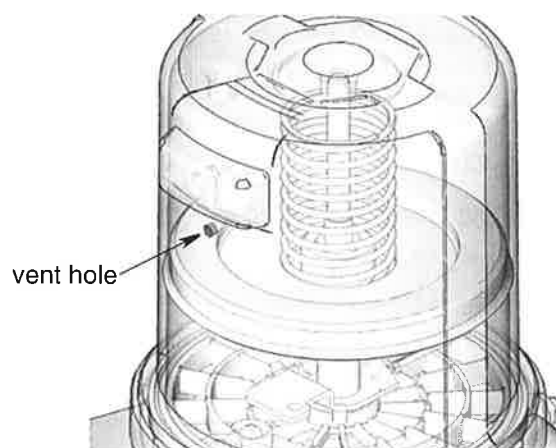

FIG. 24

NOTE: Vent port, located in rear of reservoir, should not be used as an overfill port/indicator.

4. Remove fill hose.

Changing Greases

When changing greases, always use compatible fluids or greases.

Auto-Fill Shut Off

Loading Grease

To ensure optimal performance from the G3:

- Only use NLGI #000 - #2 greases appropriate for your application, automatic dispensing, and the temperature. Consult with machine and lube manufacturer for details.
- Do not overfill.
- Do not operate G3 without reservoir attached.

NOTICE

Care must be used when filling the reservoir using a pneumatic or electric transfer pump to not pressurize and break the reservoir.

Changing Greases

When changing greases, always use compatible fluids or greases.

The Auto-Fill Shut Off is used for refilling the G3 reservoir in an automatic lubrication system. As fluid is added to the reservoir, it pushes the plate valve up to the top of the reservoir. The plate valve then pushes the valve pin and closes the inlet fluid path.

When the fluid refilling path closes, the refilling line pressurizes and brings the refilling pump to a pressurized stall condition.

NOTE: The operator must monitor system while filling the reservoir to prevent overfilling.



The remote filling station pump stalls (dead-heads) when the reservoir is full, causing the supply system pressure to rise to the maximum output pressure of the filling station pump. To help prevent equipment damage or serious injury caused by pressurized fluid, such as skin injection or injury from splashing fluid, always use a remote filling station pump with a maximum output pressure of 5100 psi (35.1 MPa, 351.6 bar) and use supply hoses with a minimum pressure rating of 5100 psi (35.1 MPa, 351.6 bar).



COMPONENT RUPTURE HAZARD
 The maximum working pressure of each component in the system may not be the same. To reduce the risk of over-pressurizing any component in the system, be sure you know the maximum working pressure of each component. **Never** exceed the maximum working pressure of the lowest rated component in the system. Over-pressurizing any component can result in rupture, fire, explosion, property damage and serious injury.

Regulate input pressure to the remote fill pump so that no fluid line, component or accessory is over pressurized.

Remote Fill with Remote Fill Manifold

The reference letters used in the following instructions refer to the Typical Installation diagram, page 11.

The fill valve is used to relieve pressure in the refill line and to reset the Auto Fill Shut Off. See Fill Valve instruction manual 333393. Graco fill valve, part no. 77X542 is available. Contact your local Graco distributor.

1. Pull out and hold the Pressure Relief Knob (T) long enough to relieve line pressure between Fill Manifold (N) and Auto-Fill Shut Off Valve (B).
2. Verify the Auto-Fill Shut Off (B) pin is down, indicating it is reset (FIG. 25).

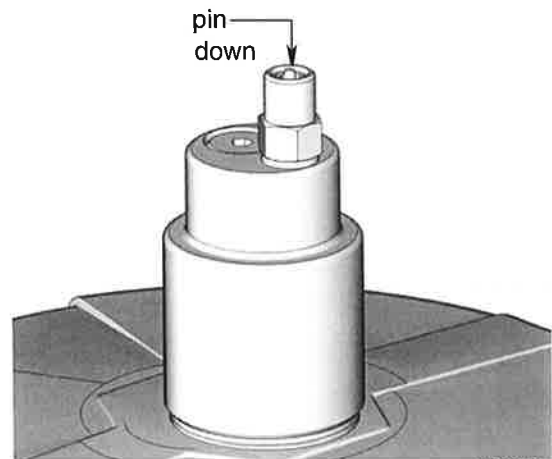

FIG. 25

t28218a

3. Remove yellow Dust Cover from Fill Coupler (M).

4. Connect Supply Hose (J) between the Remote Filling Station Pump (F) and Fill Coupler port marked with an "I".
5. Start Remote Filling Station Pump (F).
6. When the G3 Reservoir (D) is filled:
 - the Remote Filling Station Pump (F) stalls (dead-heads),
 - the Auto-Fill Shut Off (B) pin pops up as shown in FIG. 26,
 - the Pressure Gauge (R) rises to the fill pump's set pressure.

NOTE: If the pump does not stall (dead-head) there is a leak in the system.

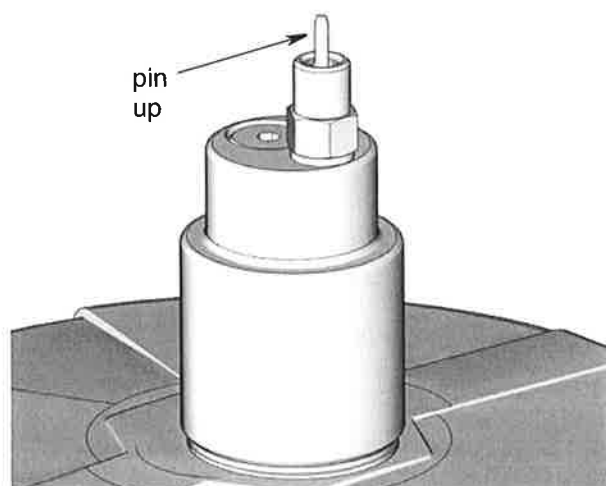

ti28219a

FIG. 26

7. Turn off the Remote Filling Station Pump (F).
8. Pull out and hold the Pressure Relief Knob (T) long enough to relieve line pressure between Fill Manifold (N) and Auto-Fill Shut Off Valve (B) and between Remote Filling Station Pump (F) and Fill Manifold (N).

NOTE: The length of time it takes to vent varies depending on the system design and installation. In some installations it may be necessary to repeat Step 8 to ensure pressure is relieved.

9. Disconnect Supply Hose (J) at Fill Coupler (M).
10. Replace yellow Dust Cover over Fill Coupler (M).

Remote Fill without Remote Fill Manifold

The reference letters used in the following instructions refer to the Typical Installation diagram, page 12.

1. A supply hose pressure relief valve (Y) and overflow container (W) (for collecting excess fluid that drains during pressure relief) **must** be installed in an easily accessible location between the remote filling station pump (F) and the Auto-Fill Shut Off (B). This pressure relief valve is used to relieve pressure in the refill line and to reset the Auto-Fill Shut Off. See Typical Installation, starting on page 12.

A Pressure Relief Kit: 247902 is available from Graco. Contact your distributor or Graco Customer Service for additional information about this kit.

2. Connect Supply Hose (J) at Quick Connect (V).
3. Turn on remote filling station pump (F) and fill the G3 reservoir (D) until the indicator pin on the Auto-Fill Valve pushes up as shown in FIG. 27. The pressure in the refill pump (F) builds and the pump stalls.

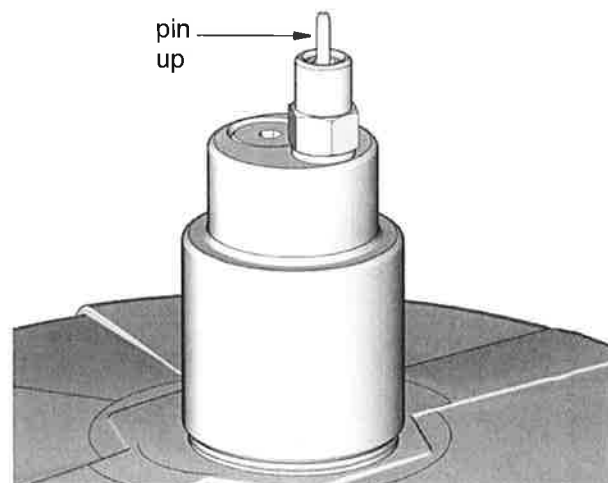

ti28219a

FIG. 27

4. Turn off the air supply (H) to pump (F).
5. Relieve remote filling station pump pressure using the following Remote Filling Station Pressure Relief procedure:

Remote Filling Station Pressure Relief

The reference letters used in the following instructions refer to the Typical Installation diagrams starting on page 10.



The following Pressure Relief Procedure is only used with the Auto-Fill Shut Off Valve to relieve remote filling station and lubricant supply line pressure.



This equipment stays pressurized until pressure is manually relieved. To help prevent serious injury from pressurized fluid, such as skin injection, splashing fluid and moving parts, follow the Pressure Relief Procedure when you stop dispensing and before cleaning, checking, or servicing the equipment.

- a. To relieve pressure between the Refill Pump (F) and Auto-Fill Shut Off (B), open ball valve (bv) (FIG. 28). Pressure will be released and excess fluid will drain out of the drain tube (L) and into the lubrication overflow container (W).

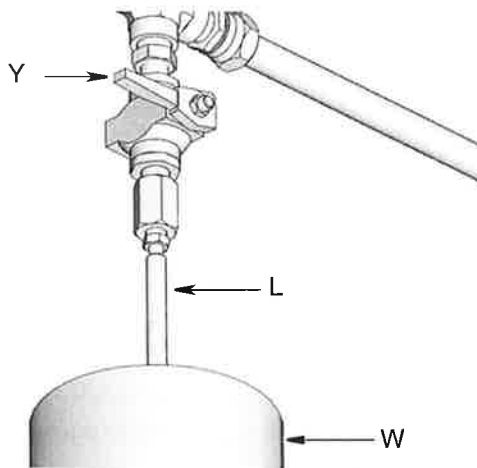

FIG. 28:

- b. Close supply hose pressure relief valve (Y) when all pressure has been relieved.
6. Disconnect the supply hose (J) from Quick Connect (V).

Filling Oil Unit

- Only use oil appropriate for your application, automatic dispensing, and the equipment's operating temperature. Consult with machine and lube manufacturer for details.
- Do not overfill (FIG. 29).
- Do not operate G3 without reservoir attached.
- Only use oils with viscosity at least 40 cSt.

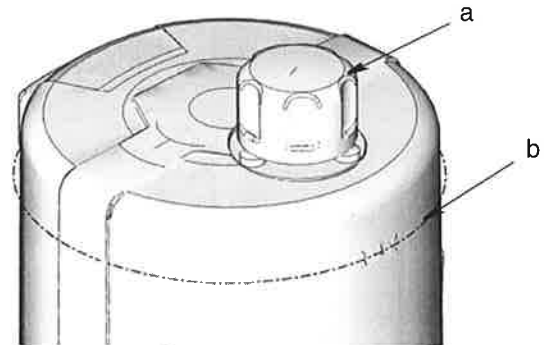

FIG. 29

1. Remove fill cap (a).
2. Pour oil into reservoir to max fill line (b).
3. Replace fill cap. Hand tighten cap, securely.

Priming

NOTE: It is not necessary to prime pump every time pump is filled with lubricant.

Pump only requires priming the first time it is used or if it is allowed to run dry.

1. Loosen pump element fitting (Fig. 30).

NOTE: When loosening pump element fitting, do NOT loosen **pump element**. Loosening pump element will change the output volume

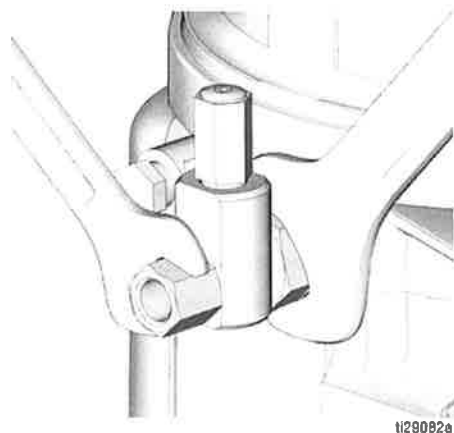

FIG. 30

2. Only run pump until air is no longer dispensed with the lubricant coming out of element fitting (Fig. 31).

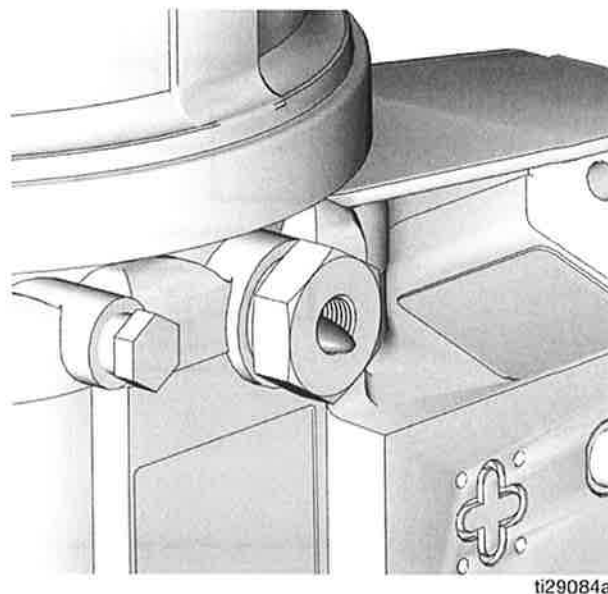
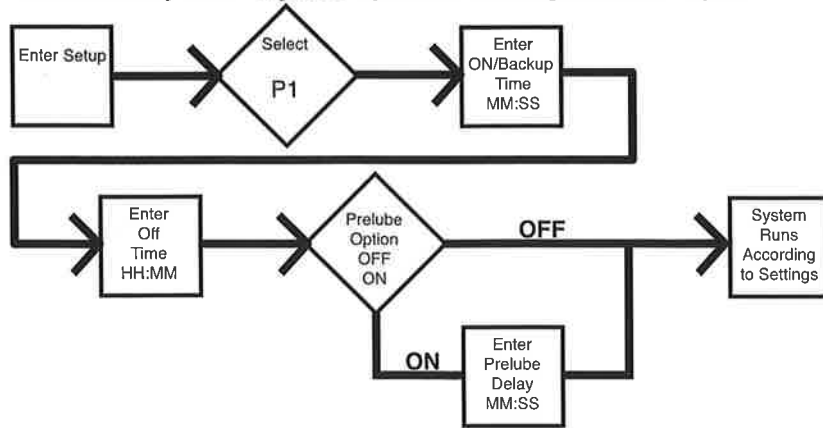

FIG. 31

3. Tighten pump element fitting using two wrenches working in opposite directions (Fig. 30).

Quick Setup Guide

Max Model System - Injector System with Single Sensor Input



Max Model System - Divider Valve System with Single Sensor Input

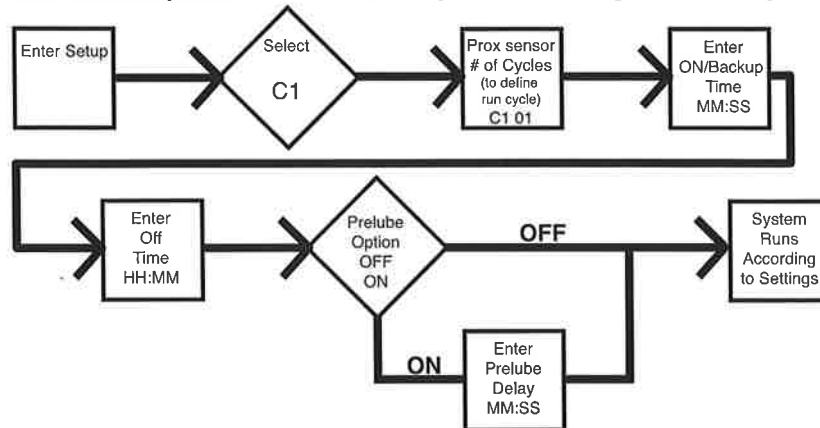

Max Model Setup

Control Panel Overview (FIG. 32)

NOTE: Programming instructions begin on page 30.

ON TIME/BACKUP TIME

- LED lights when ON Time/Backup Time is running.
- Display shows time as MM:SS (minutes and seconds). i.e., 08:30 is 8 minutes: 30 seconds.
- Sets the limits for the amount of time to complete a cycle or build up pressure before a warning is activated.
- Counts down from a set time to zero.

DISPLAY

- A blinking LED under HH, MM, SS or ## identifies type of measurement unit you are setting; i.e., HH is hours.
- A blinking number on the display indicates the G3 is in SETUP MODE.
- In RUN MODE displayed numbers count up or down. See Time ON and Time OFF.

OFF TIME/BACKUP TIME

- LED lights when OFF Time/Backup Time is used to control Pump OFF function.
- Value is entered in HH:M.
- Displays in HH:MM (hours and minutes) when > 1 hour.
- Times pump rest between cycles.
- Counts down from set time to zero.
- Can be set up to use as a backup for Machine Count control.

CYCLE / PRESSURE SETUP

- Sets either Cycle (C) or Pressure (P) Monitoring limits for up to 3 sensors.
- Each sensor is set up and controlled independently.

MACHINE COUNT

- LED lights when Machine Count is used to control Pump OFF function.
- Counts independent machine operations with a sensor to control Pump Off duration.
- Time OFF function can be used as a backup for Machine Count.

LEFT DIRECTION ARROW / RESET

- In SETUP MODE: moves cursor in display one field to the left.
- In RUN MODE: single press clears warning.
- In RUN MODE: pressing for one second ends run cycle if no warnings.
- In ALARM MODE: pressing and holding for 3 seconds clears fault / warning and switches cycle to OFF MODE.

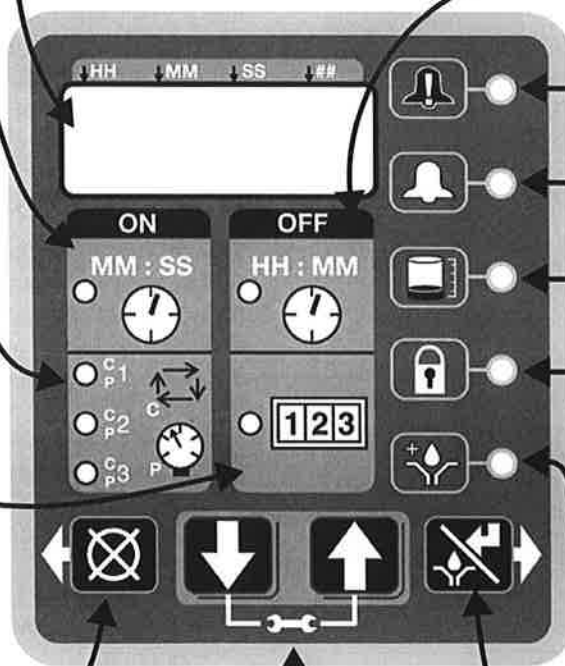

ALARM ICONS

LED next to icon lights when a fault / warning event occurs during a run cycle. See page 59 for a complete description of these alarm scenarios.

PIN ICON

- LED next to icon lights indicating PIN is required to enter setup.
- In SETUP MODE LED lights when setting up the PIN.

PRELUBE

LED next to icon lights indicating LED lights when Prelube function is enabled.

UP and DOWN ARROW

- Hold both the UP and DOWN ARROW buttons down together for 3 seconds to enter SETUP MODE.
- In SETUP MODE: increases or decreases number values shown in display.

RIGHT DIRECTION ARROW / MANUAL RUN / ENTER

- In SETUP MODE: saves entry, moves cursor in display one field to the right or to the next setup step.
- In RUN MODE: starts a manual run cycle.

FIG. 32

Programming the Max Model

Checking the Firmware Version

To check the firmware version installed on the pump:

1. Remove power to the pump by disconnecting the power cable from the connection.
2. Reconnect the power cable to the power connection.

This creates a power cycle and the firmware version displays on the screen during the first few seconds of power up. See FIG. 33.



FIG. 33

Powering Units With Controllers

By default, units with controllers are set to operate in a timed mode with 1 minute of ON time and 8 hours of OFF time. The unit should be powered up in OFF mode, counting down from the 8 hours. If the unit powers up in ON mode and has not been primed, hold the reset button located on the control panel (example shown on the right) for 1 second to move to the OFF mode.



NOTE:

- A blinking number on the display indicates the G3 is in SETUP MODE.

- In RUN MODE numbers on the display do not blink.
- After 60 seconds of no activity, the device returns to RUN MODE in the OFF Time cycle and the OFF Time restarts counting down the total programmed amount of time. It does **not** resume the countdown from the point where the cycle was interrupted when you entered SETUP MODE.

Entering Setup Mode

Press both the UP and DOWN ARROW buttons together for 3 seconds to enter the SETUP MODE.

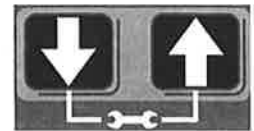

NOTE: If the lock LED is lit after entering Setup Mode and four 0000's are displayed, the unit has a PIN Code lock out enabled. See the following section: Entering a PIN Code to Access Setup Mode.

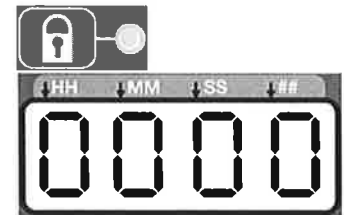

Entering a PIN Code to Access Setup Mode

The G3 controller does not require a user to provide a PIN code to access the programming features of the unit. However, Graco understands that some users may want to protect the programming settings and therefore, an option for adding PIN Code authorization is available. The instructions for setting up PIN Code Authorization are provided in the Advanced Programming section of this manual. See page 47.

To enter the PIN Code:

1. Press both the UP and DOWN ARROW buttons for 3 seconds.



2. The LED next to the LOCK ICON on the display lights and the 4 zeros appear on the display indicating the system requires a PIN Code entry to run the G3 in SETUP MODE.



3. The cursor is automatically positioned to enter the first character of the PIN Code. Use the UP and DOWN ARROW buttons to move up



and down through the numbers 0-9 until the first number in the PIN code is displayed in the field.

4. Press the ENTER button to set the number. The cursor automatically moves to the next number field. 
5. Repeat steps 3 and 4 for each PIN Code prompt field.

If the PIN Code you entered is correct, the first editable character on the display will flash.

NOTE: A blinking field on the display indicates the G3 is in SETUP MODE. In RUN MODE numbers on the display will not blink.

Setting the Real Time Clock



DMS™ Equipped Models Only

NOTE: Set the real time clock prior to plugging the USB flash drive into the pump.

Enter the Year:

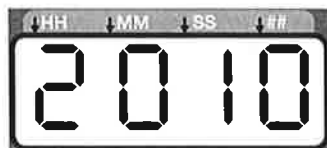
- The year displays. The first programmable character, the decade, blinks indicating the device is ready to program the decade digit of the year.
- The LED under the # sign lights while setting the year.



1. Use the UP and DOWN arrow buttons to move up and down through the number 0-9 until the number for the current decade is displayed in the field. 
2. Press the ENTER button to set the decade number. The cursor automatically moves to the next field, the year number. 
3. Use the UP and DOWN arrow buttons to move up and down through the number 0-9 until the number for the current year is displayed in the field. 

4. Press the ENTER button to set the year number. 

The 3-character month displays indicating the G3 is now ready to program the month.

Enter the Month:



1. Set the 3 character month by using the UP and DOWN ARROW buttons to move up and down through the list of months until the current month is displayed in the field. 

2. Press the ENTER button to set the month. 



The 2-digit date displays indicating the G3 is now ready to program the date.

Enter the 2-digit Date:

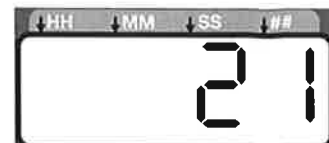
The first programmable character of the 2-digit date blinks indicating the device is ready to program the first digit of the date.



The LED under the # sign lights while setting the date.

1. Use the UP and DOWN ARROW buttons to move up and down through the numbers 0-3 until the first digit of the date is displayed in the field. 
2. Press the ENTER button to accept the selection. The cursor automatically moves to the second digit of the date. 
3. Use the UP and DOWN ARROW buttons to move up and down through the numbers 0-9 until the second digit of the date is displayed in the field. 

4. Press the ENTER button to set the date.



The time displays indicating the G3 is now ready to program the time.

Enter the Time:

- The time displays in 24-Hour format. i.e., 2:45 PM displays as 14:45.
- The clock is set in Hours and Minutes (HH:MM).
- The LED under the HH lights when setting hours and the LED under the MM lights when setting minutes.
- The first programmable number of the HH (hour) filed blinks, indicating the device is ready to program the first digit of the hour.
- When programming a time of less then 12 hours, you must program a leading zero in the first number field and press the ENTER button to save the zero.



1. Use the UP and DOWN ARROW buttons to move up and down through the numbers 0-2 until the desired number appears in the first hour (HH) field.



2. Press the ENTER button to set the number.



3. Use the UP and DOWN ARROW buttons to move up and down through the numbers 0-9 until the desired number for the second HH number field appears.

4. Press the ENTER button to set the number.



5. The next number field to the right blinks and the LED under the MM lights indicating the G3 is ready to program the minutes fields.

6. Repeat steps 1-4 to set the minutes (MM) fields.

7. After pressing the ENTER button to set the time, the programmed Time information is saved.



Programming ON Duration

- OFF, C1 (C2, C3) or P1 (P2, P3) displays, identifying the function you are programming.
- Selection of OFF, C1 (C2, C3) or P1 (P2, P3) designates the way pump run time is controlled:
 - C1, C2, C3 - Completing a specific number of cycles measured by an external prox/cycle switch
 - P1, P2, P3 - Reaching a specific pressure threshold measured by an external pressure switch - **OR**,
 - OFF - A specific duration of time elapses.
- The LED next to C/P1 lights, indicating which sensor of the pump control you are programming using either a specific number of cycles or by monitoring a pressure switch.
- C / P2 and C / P3 controls functions to the second and third sensors (when sensors are used).
- Only sensor inputs that are available on the unit can be programmed.



NOTE: Field cannot be left blank. If C / P2 and C / P3 are not used, OFF must be entered instead.

Cycle (C1, C2, C3) Setup

Cycle controls the number of lube cycles (as monitored by an external cycle monitor) completed before the pump rests.

NOTE:

- You must program at least **one** cycle. Zero is not an available option.

1. Use UP or DOWN arrow button to toggle display between OFF / C1 / P1 on the display.

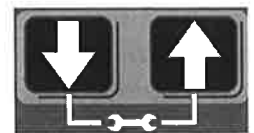

2. When C1 is on display, press the ENTER button to save selection and begin programming Cycle data.

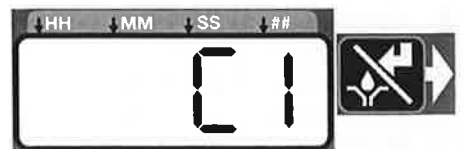

- The first number displayed after the "C1" on the display blinks, indicating the device is ready to program the number of C1 cycles.



- The LED under the # sign lights when setting the number of cycles.

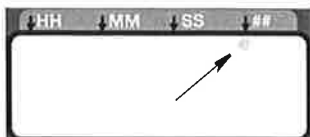

3. Program the number of cycles by pressing the UP or DOWN ARROW button to move up or down through number 0-9.



4. The cycle field is a 2 digit number. When the correct first numeral of the number displays, press the ENTER button to save the number. The cursor automatically moves to the second number field.



NOTE: A leading zero (0) must be entered in the first field if the number of cycles is fewer than 10.

5. Press the ENTER button, to save the C1 information.



- If your G3 is equipped with more than one sensor input, you will automatically be prompted to begin selecting the pump control type for the next sensor. Repeat steps 1 - 5 to program cycles for C2 and C3.



NOTE: If C / P2 and C / P3 are not used, the default OFF setting must be entered instead.

6. After you set the last field and press the ENTER button, the G3 saves the Cycle information and moves to setting Backup Time, page 36.



Pressure Control (P1, P2, P3) Setup

- For injector systems, monitoring pressure can be used as a way to ensure sufficient pressure has been reached to activate injectors. The pump runs, building up enough pressure to cause injectors to dispense fluid. Pressure continues to build to a pre-set maximum, activating the (user supplied) pressure switch. Then an external (user supplied) vent valve opens and pressure reduces, priming the injector for the next cycle.

- Pressure control is an ON / OFF selection only.

1. Use the UP or DOWN arrow button to toggle between OFF / C1 / P1.



2. When P1 displays, press ENTER button to save selection.

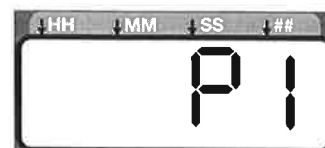

3. If your G3 comes equipped with more than one sensor input, you will automatically be prompted to begin selecting pump control type for the next sensor. Repeat steps 1 - 2 to program P2 and P3.

If P1 / P2 / P3 is selected the vent valve time is automatically set to 5 minutes. If the unit is used in an injector based system and a sensor input is not used, the user must update the vent valve time in advanced programming. (See Advanced Programming, A-3 Vent Valve Time, page 48.)

Input Not Used

Select OFF if your system does not use the applicable input.

1. Use UP or DOWN arrow button to toggle between OFF / C1 / P1 on the display.



2. When OFF is on



the display, press the ENTER button to save selection.

If the sensor inputs are available and none are used in the ON Mode, the definition of the entered time is ON TIME.

Examples:

Model G3-G-24MX-2LFL00-1DMVA2R3 has 4 sensors, so C/P1, C/P2, and C/P3 and Machine Count can all be programmed.

Model G3-G-24MX-2LFL00-10CV00R0 has 1 sensor, only C/P1 is available for programming.

Backup Time

In both Cycle and Pressure Modes, a maximum run Time (Backup Time) for the lubrication period must be set up. If this Time expires before the lubrication is completed an alarm/warning is triggered and the pump stops.

To determine the Backup Time, Graco recommends the user verify the length of time it takes to complete a typical cycle and double that value (to a maximum of 30 minutes).

Backup Time is setup after Cycle or Pressure Sensor Setup is complete.

NOTE:

- The LED next to the clock in the ON field lights, indicating the Backup Time is being programmed.
- BACKUP (ON) Time is set as minutes and seconds (MM:SS) only.
- The small flashing LED under the MM indicates you are setting minutes.
- The first field (left side of display) blinks indicating the device is ready for you to begin programming.

Programming Backup Time

NOTE: When programming a time of less than 10 minutes you **must** program the leading zero in the first number field and press the ENTER button to save the zero selection.

1. To set the ON Time use the UP or DOWN ARROW button to scroll through numerals 0 to 5 until the desired number appears in the first MM (minutes) field.

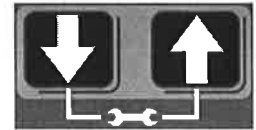

2. Press the ENTER button to lock in the selection. The next MM number field to the right flashes indicating it is ready for programming.



3. Use the UP or DOWN ARROW button to scroll through numerals 0 to 9 until the desired number appears in the second MM number field.

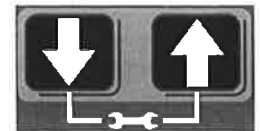

4. Press the ENTER button to lock in the selection.



The next number field to the right flashes and the LED lights under SS; indicating it is ready to program the seconds fields.

5. Repeat steps 1 - 4 to set the SS (seconds) fields.
6. After pressing the ENTER button to set the last SS field, all the programmed ON Time information is saved.



The G3 automatically switches to the OFF Time SETUP MODE.

ON Time

- The LED next to the clock in the ON field lights, indicating you are setting the ON Time parameters.



- ON Time is set in Minutes and Seconds (MM: SS).

- An LED flashes under either MM when programming minutes **OR** SS when programming seconds.

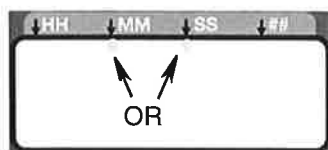

- In SETUP MODE, the number displayed in the first field, on the left side of display blinks, indicating the device is ready to program the ON Time minutes.

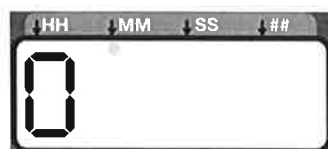

- The total amount of ON Time cannot exceed 30 minutes. If a value greater than 30 minutes is entered, the RED alarm LED lights and the value must be updated.



If this time does not meet the application needs, contact Graco Customer Support.

Programming ON Time

NOTE: When programming a time of less than 10 minutes you **must** program a leading zero in the first number field and press the ENTER button to save the zero selection.

- To set the ON Time use the UP or DOWN ARROW button to scroll through numerals 0 to 5 until the desired number appears in the first MM (minutes) field.



- Press the ENTER button to lock in the selection. The next MM number field to the right flashes indicating it is ready for programming.



- Use the UP or DOWN ARROW button to scroll through numerals 0 to 9 until the desired number appears in the second MM number field.



- Press the ENTER button to lock in the selection.



The next number field to the right flashes and the LED lights under SS; indicating it is ready to program the seconds fields.

- Repeat steps 1 - 4 to set the SS (seconds) fields.

- After pressing the ENTER button to set the last SS field, all the programmed ON Time information is saved.



The G3 automatically switches to the OFF Time SETUP MODE.

PUMP OFF / REST Setup

After setting the parameters for either Cycle (C1, C2 or C3) or Pressure (P1, P2, or P3) ON modes, the OFF or pump rest cycle must be set up. There are 3 ways to control this function:

- Machine Count switch activation, or
- Machine Count activations limited by a maximum Time, or
- A specific set amount of Time (similar to Time Mode).
- If the machine count sensor input is available and not used in the OFF Mode, the definition of the entered time is OFF TIME.

Machine Count

- After you set the last ON Time field and press the ENTER button, the G3 automatically switches to the Machine Count setup if your model has this feature.



Notice the LED next to 123 on the G3 display lights indicating you are now in the Machine Count setup mode.

- Press the UP or DOWN ARROW button to move up or down through number 0-9.



- When the correct number displays, press the ENTER button to set the number.



NOTE: If the machine count input is available on the unit and not used, the value **MUST** be set to zero (0).

- Repeat 2 - 3 to set the remaining fields.

NOTE: After the Machine Count value is entered, the G3 can be programmed to backup the machine count input with time.

Backup Time Setup

1. The OFF Time LED lights.



OFF displays.



2. Press the UP or DOWN ARROW button to change OFF to RUN or FLT on the display.

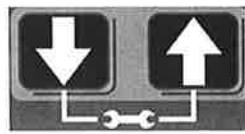

- RUN: After backup time expires the pump automatically goes into an ON cycle and shows a machine count warning.



- FLT: After backup time expires, the pump automatically goes into a fault mode.



3. Press the ENTER button to set the selection.



Backup Time

- The LED next to the clock in the OFF field lights, indicating you are setting the Backup Time parameters.
- OFF Time is set in Hours and Minutes (HH: MM).
- An LED flashes under either HH when programming hours **OR** MM when programming minutes.

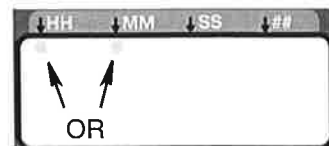

- In SETUP MODE the number displayed in the first field, on the left side of display blinks, indicating the device is ready to program the Backup Time hours.



- The total amount of Backup Time must be at least twice as long as the programmed ON Time. If a value less than twice the ON Time is entered, the RED alarm LED lights and the value must be updated.



If this time does not meet the application needs, contact Graco Customer Support.

Programming Backup Time

NOTE: When programming a Backup Time of **less than 10 hours** you **must** program a leading zero in the first number field and press the ENTER button to save the zero selection.

1. To set the Backup Time use the UP or DOWN ARROW button to scroll through numerals 0 to 9 until the desired number appears in the first HH (hour) field.

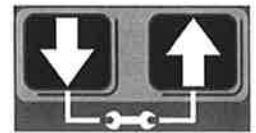

2. Press the ENTER button to lock in the selection. The next HH number field to the right flashes indicating it is ready for programming.



3. Use the UP or DOWN ARROW button to scroll through numerals 0 to 9 until the desired number appears in the second HH number field.

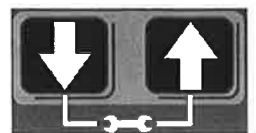

4. Press the ENTER button to lock in the selection.



The next number field to the right flashes and the LED lights under MM; indicating it is ready to program the minutes fields.

5. Repeat steps 1 - 4 to set the next MM (minutes) fields.

- After pressing the ENTER button to set the last MM field, the OFF Time information is saved.
- After selecting ON, refer to page 33.



NOTE: Backup time can be set in HH:MM for the machine count input.

OFF Time

- The LED next to the clock in the OFF field lights, indicating you are setting the OFF Time parameters.
- OFF Time is set in Hours and Minutes (HH: MM).



- An LED flashes under either HH when programming hours OR MM when programming minutes.

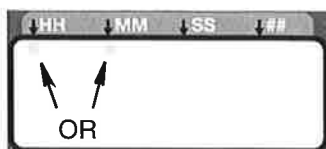

- In SETUP MODE the number displayed in the first field, on the left side of display blinks, indicating the device is ready to program the OFF Time hours.

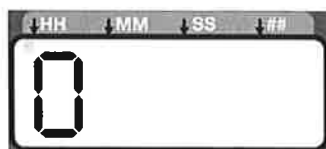

- The total amount of OFF Time must be at least twice as long as the programmed ON Time. If a value less than twice the ON Time is entered, the RED alarm LED lights and the value must be updated.



If this time does not meet the application needs, contact Graco Customer Support.

Programming OFF Time

NOTE: When programming a time of **less than 10 hours** you **must** program a leading zero in the first number field and press the ENTER button to save the zero selection.

- To set the OFF Time use the UP or DOWN ARROW button to scroll through numerals 0 to 9 until the desired number appears in the first HH (hour) field.

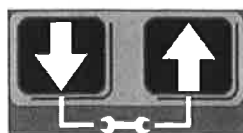

- Press the ENTER button to lock in the selection. The next HH number field to the right flashes indicating it is ready for programming.



- Use the UP or DOWN ARROW button to scroll through numerals 0 to 9 until the desired number appears in the second HH number field.

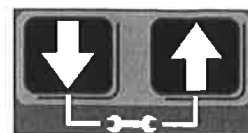

- Press the ENTER button to lock in the selection.



The next number field to the right flashes and the LED lights under MM; indicating it is ready to program the minutes fields.

- Repeat steps 1 - 4 to set the next MM (minutes) fields.
- After pressing the ENTER button to set the last MM field, the OFF Time information is saved.



Prelube

The Prelube function determines operation of the pump when power is applied. It can be set to OFF or ON.

OFF (default) - The unit resumes its lubrication cycle at the point it was at when power was removed.

ON - The unit begins a pump cycle.

Setting Prelube

- After you set the OFF Time information and press the ENTER button, the G3 automatically switches to the Prelube Delay setup.

Notice the LED next to the prelube icon on the G3 display lights indicating you are now in the Prelube setup mode.



- OFF displays. If you want the prelube cycle to begin immediately, leave this set to OFF.



- Press the ENTER button to set the selection.



- If you want to set a prelube delay time, press the DOWN ARROW button to change OFF to ON on the display.



Prelube Delay

Prelube Delay can be entered to delay the start of the pump's cycle on power up. If prelube is set to ON, a prelube delay time in MM:SS must be entered. By default, the delay is set to 0 (begin an ON cycle immediately).

Delaying the prelube function may be desired if other critical functions or systems of your machine or vehicle are also coming on line during power up.

- Prelube Delay is set in MM:SS (minutes and seconds). To set the time use the UP or DOWN ARROW button to scroll through numerals 0 to 5 until the desired number appears in the first MM (minutes) field.



The maximum length of time Prelube Delay can be set to is 59:59 (59 minutes:59 seconds).

- Press the ENTER button to lock in the selection. The next MM number field to the right flashes indicating it is ready for programming.



- Use the UP or DOWN ARROW button to scroll through numerals 0 to 9 until the desired number appears in the second MM number field.

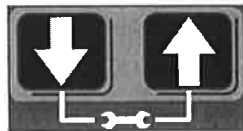

- Press the ENTER button to lock in the selection.



The next number field to the right flashes and the LED lights under SS; indicating it is ready to program the seconds fields.

- Repeat steps 1 - 4 to set the SS (seconds) fields.
- After pressing the ENTER button to set the last SS field the G3 automatically switches to the RUN MODE.



DMS™ Models Only

Downloading Data

- Plug the USB flash drive into the USB port.

NOTE: The G3 pump stops pumping as soon as the USB flash drive is plugged into it.

- The system automatically begins downloading data to the USB drive.

- "data" is displayed while the system is downloading files.

data

- When download is finished, "done" is displayed.

done

- G3 pump restarts cycle in the OFF mode.
- Remove the USB flash drive.

Storing Pump Program Settings to the Flash Drive

The pump program settings file is named either:

GRACO/G3Config/g3config.bin (for 0209 and earlier versions) or GRACO/Config/config.bin (for 0706 and later versions): This file cannot be modified. Modification of the file or file name (by anyone but the issuer) may cause it to be unusable.

- Plug the USB flash drive into the USB port.

NOTE: The G3 pump stops pumping as soon as the USB flash drive is plugged into it.

- The system automatically begins downloading data to the USB drive.

- "data" is displayed while the system is downloading files.

data

- When download is finished, "done" is displayed.

done

- G3 pump restarts cycle in the OFF mode.
- After the download is complete, press and hold the UP



and DOWN ARROW button for 3 seconds to store the current setup to the USB flash drive.

7. "data" is displayed while the unit is downloading and storing the configuration on the USB drive. 

8. When configuration is stored, "done" is displayed. 

9. G3 pump restarts cycle in the OFF mode.

10. Remove the USB flash drive.

Uploading Pump Program Settings to the Pump

1. Plug the USB flash drive into the USB port.

NOTE:

- The USB flash drive must contain file GRACO/G3Config/g3config.bin (for 0209 and earlier) or GRACO/Config/config.bin (for 0706 or later).

NOTE: 0707 pumps can take either file setting to upload, but earlier pumps cannot. File names and folders may need to be changed manually when importing settings to an earlier version pump from a later version.

- The G3 pump stops pumping as soon as the USB flash drive is plugged into it.

2. The system automatically begins downloading data to the USB drive.

3. "data" is displayed while the system is downloading files. 

4. When download is finished, "done" is displayed. 

5. G3 pump restarts cycle in the OFF mode.

6. After the download is complete, press and hold the RESET button and UP ARROW button for 3 seconds to upload the setup stored in the USB flash drive. 

7. "data" is displayed while the unit is uploading the configuration data. 

8. When upload is finished, "done" is displayed. 

9. G3 pump restarts cycle in the OFF mode.

10. Remove the USB flash drive.

11. After the USB flash drive is removed, press and hold the UP and DOWN ARROW buttons for 3 seconds to enter the SETUP MODE (see Entering Setup Mode, page 30). 

12. In SETUP MODE, set the YEAR, MONTH, DATE and TIME (see Setting the Real Time Clock, page 31).

13. After pressing the ENTER button to set the TIME, press the RESET button to exit the SETUP MODE. 

Viewing the UNIT DMS ID Number

1. In RUN mode, press and hold the DOWN ARROW button. 

2. The Unit DMS ID number displays. The unit continues to normal operation while the DMS ID is displayed.

3. Release the DOWN ARROW button after viewing the DMS ID number.

Operation / Data Log

During operation the G3 Pump stores information as Log and Summary Files.

Logs contain the following information:

- Log Name
- DMS ID Number
- Current Software Graco Part Number
- Current Software Version
- Date and Time of Upload

System Event Log

The System Event Log lists the date and time of the last 800 common system events such as pump cycles, manual run and setting changes. The most recent event is listed first.

The log file is stored in a folder structure created by the pump DMS ID and download date. If multiple downloads are done on the same date, the existing files will be written over.

The folder structure is as follows:

GRACO/G3_{DMS_id}/{download date - YYYYm-mDD}/EVENTLOG.CSV

Example: GRACO/G3_00025/20100911/EVENT-LOG.CSV.

Sample System Event Log

Example Event Log 1: Pump cycle of a divider valve system with a proximity switch set to detect 5 divider valve cycles.

G3 System Event Log
DMS ID Number: 0025 (see page 39)
Software Part Number: 16F821
Software Version: 1019
09/29/2010 14:1400

Date	Time	Description
9/29/2010	14:13:02	Pump Run Off
9/29/2010	14:13:02	C1 Cycle Completed
9/29/2010	14:12:39	C1 Cycle Detected
9/29/2010	14:12:34	C1 Cycle Detected
9/29/2010	14:12:28	C1 Cycle Detected
9/29/2010	14:12:23	C1 Cycle Detected
9/29/2010	14:12:17	Pump Run On

Example Event Log 2: Pump cycle of an injector valve system with a pressure switch feedback.

Date	Time	Description
9/29/2010	13:28:12	Venting Completed
9/29/2010	13:23:12	Venting Detected
9/29/2010	13:23:11	Pump Run Off
9/29/2010	13:23:11	P1 Pressure Completed
9/29/2010	13:22:20	Pump Run On

Common System Events are listed below.

Pump Run On	The pump entered an on cycle and is operating and dispensing material.
Pump Run Off	The pump entered an off cycle and is not dispensing.
Pump Run Canceled	A pump on cycle was canceled by pressing the cancel button on the front panel and holding it for 3 seconds.
G3 Power On	The pump powered on.
G3 Power Off	The pump powered off.
Program Variable Change	The setup mode was entered.
C1 Cycle Detected	The system is set up to monitor a proximity switch on a divider valve using the sensor input (C1, C2, and/or C3) and has detected one divider valve cycle.
C2 Cycle Detected	
C3 Cycle Detected	
C1 Cycle Completed	The system is set up to monitor a proximity switch on a divider valve using the sensor input (C1, C2, and/or C3) and has achieved the number of counts required by the system for that input, completing a pump on cycle.
C2 Cycle Completed	
C3 Cycle Completed	
P1 Pressure Completed	The system is set up to monitor a pressure switch for an injector system using sensor input (P1, P2, and/or P3), the system has achieved pressure and the switch has activated, completing a pump on cycle.
P2 Pressure Completed	
P3 Pressure Completed	
Machine Count Completed	The system is set up to monitor a sensor on the equipment being lubricated using the machine count input and has achieved the number of counts required by the system for that input, completing a pump off cycle and initiating a pump on cycle.
Local Manual Run Initiated	The manual run button was pressed, initiating a pump on cycle.
Remote Manual Run Initiated	The remote manual run button was pressed initiating a pump on cycle.

Venting Detected	In an injector system, the pump on cycle has completed and the system is currently venting pressure through the vent valve.
Venting Completed	in an injector system, the system completed the vent time.
Prelube Initiated	The pump has entered a prelube delay after powering up.
Prelube Completed	The pump has completed prelube delay and will begin a pump on cycle.
Successful Pin Code Entry	The pin code was successfully entered and the user has entered setup mode.
Firmware Update Completed	The firmware was updated.

Error Log

The Error Log lists Set Time and Clear Time for the last 400 faults and warnings. The most recent event is listed first.

The log file is stored as:

GRACO/G3_{DMS_id}/{download date - YYYYm-mDD}/ERRORLOG.CSV

Example: GRACO/G3_00025/20100911/ERRORLOG.CSV.

Sample Error Log

G3 Error Log

DMS ID Number: 00025 (see page 39)

Software Part Number:16F821

Software Version:0205

12/31/2015 23:04:00

Date	Time	Description
12/31/2015	23:03:54	Low Level Cleared
12/31/2015	23:03:42	Low Level Fault
12/31/2015	23:03:32	Low Level Warning
12/31/2015	23:03:22	P2 Not Detected Cleared
12/31/2015	23:03:22	C1 Not Detected Cleared
12/31/2015	23:03:19	P2 Not Detected
12/31/2015	23:03:19	C1 Not Detected
12/31/2015	23:02:20	Machine Count Not Detected
12/31/2015	23:02:11	Machine Count Not Detected

Common Error Log entries are listed below.

Software Fault	An internal software error occurred. Contact Graco Customer Service.
Low Level Warning	The unit entered a low level warning mode and is running low on material. The pump continues to dispense material for the duration of the low level alarm time specified by the unit.
Low Level Fault	The alarm time in low level warning has elapsed. The unit will not pump until the reservoir is filled and the fault is cleared.
Cycle 1 Not Detected	In a divider valve system, the system has not received the programmed number of divider valve cycles for the specified input in the programmed backup time.
Cycle 2 Not Detected	
Cycle 3 Not Detected	
Pressure 1 Not Detected	In an injector system the system has not received a signal from the pressure switch in the designated backup time.
Pressure 2 Not Detected	
Pressure 3 Not Detected	
System Already Pressurized 1	In an injector system the pressure switch is activated when the unit enters a pump on mode and may not have vented properly.
System Already Pressurized 2	
System Already Pressurized 3	
Machine Count Sensor Failure	The specified number of machine count input activations was not received within the designated backup time.
Motor Overcurrent	The unit is out of expected motor current range. Check the system to determine that it is functioning correctly (i.e., no blocked lines). Continued operation at excessive motor currents will cause degradation in pump life.

High Temperature Warning	Internal temperature of the unit is above the designated operating. Check the unit and system to determine that it is functioning correctly. Operating outside of the specified temperature range may cause reduced performance and possible unit failure.
Low Temperature Warning	Internal temperature of the unit is below the designated operating. Check the unit and system to determine that it is functioning correctly. Operating outside of the specified temperature may cause reduced performance and possible unit failure.
USB Unable to Mount	The USB flash drive that was installed was unable to connect and communicate with the pump.
USB Unsupported Device	The USB flash drive is unsupported. Use a different flash drive.
USB File Not Found	The pump program setting file was not found or created correctly. Restore the setting file to the flash drive.
USB Folder Navigation	The pump program setting file was not found or created correctly. Restore the setting file to the flash drive.
USB Invalid File	The pump program settings file was not found or created correctly. Restore the setting file to the flash drive.
Failed Pin Code Entry	A failed attempt was made to enter the pin code password.

Functional Summary

The Functional Summary contains two types of data.

- The first report type, labeled User under the Type heading in the first column of the Sample Functional Summary, only provides data compiled since the last time the Functional Summary was reset through present day (see A6 - Clearing the Functional and Technical User Summary, page 50).

This is very similar to the resettable trip odometer in your car.

- The second report type, labeled Factory under the Type heading in the first column of the Sample Functional Summary, covers the cumulative life of the pump from the first day it was put into service through present day.

This is very similar to an odometer in your car.

The log file is stored as:

GRACO/G3_{DMS_id}/{download date - YYYYm-mDD}/FUNC SUM.CSV

Example: GRACO/G3_00025/20100911/FUNC-SUM.CSV

Sample Functional Summary

G3 Functional Summary										
DMS ID Number:00025 (see page 39)										
Software Part Number:16F821										
Software Version:0205										
12/27/2010 9:50:51										
Type	Start Date	Lube Cycles	Pump Run	Powered On	Local Manual Run	Remote Manual Run	Average Run Time	Average Input 1 Time	Average Input 2 Time	Average Input 3 Time
User	12/21/2010		210 hrs	0 hrs	2	0	0:00:01	0:00:00	0:00:00	0:00:00
Factory	9/30/2010	408	7 hrs	279 hrs	165	2	0:01:04	0:00:03	0:00:08	0:00:04
		Average Duty Cycle	Max Duty Cycle	Low Level Faults	Cycle Pressure Faults	Other Faults	Fault Hours	Low Level Warnings	Cycle Pressure Warnings	Other Warnings
		0.36%	0.36%	0	0	0	0 hrs	0	0	0
		2.63%	56.89%	10	212	21	165 hrs	13	36	26

Operation / Data Log

Common Functional Summary Data entries are listed below.

Number of Cycles	The number of lubrication cycles the unit has started.
Total Run Hours	Total amount of hours the pump has been in the ON mode of the ON/OFF cycle.
Total Powered On Hours	Total number of hours that the unit has been powered on.
Local Manual Run	The number of times the manual run button was pressed.
Remote Manual Run	The number of times the remote manual run button was pressed.
Average Run Time	The average amount of time per lubrication cycle that the pump has been running (MM:SS).
Average Cycle 1 Time	The average amount of time the unit has been operating before the specified feedback for the sensor input was received (proximity switch counts in divider valve systems and pressure switch activation in injector systems).
Average Cycle 2 Time	
Average Cycle 3 Time	
Average Duty Cycle	The average percentage of time the unit has been pumping while it has been powered on.
Max Duty Cycle	The highest percentage of time for one lubrication cycle that the unit has been pumping while it has been powered on.
Total Low Level Faults	Total number of low level faults.
Total Cycle Pressure Faults	Total number of faults related to sensor feedback in an injector or divider valve system.
Total Other Faults	Faults other than low level or sensor feedback.
Total Fault Hours	Number of hours the system has been powered on in fault mode.
Total Low Level Warnings	Number of low level warning conditions.
Total Cycle Pressure Warnings	Total number of warning conditions related to sensor feedback. This is only applicable if fault retries are used.
Total Other Warnings	All other warnings including temperature and motor current.

Technical Summary

The Technical Summary contains two types of data.

- The first report only provides data compiled since the Pump Summary was reset to present day (see A6 - Clearing the Functional and Technical User Summary).

This is very similar to the resettable trip odometer in your car.

- The second is a report that covers the cumulative life of the pump from the first day it was put into service to present day.

This is very similar to an odometer in your car.

The log file is stored as:

GRACO/G3_{DMS_id}/{download date - YYYYm-mDD}/TECHSUM.CSV

Example: GRACO/G3_00025/20100911/TECHSUM.CSV

Common Technical Summary Data entries are listed below.

Average Input Board Voltage (DC)	The average input voltage measured by the internal circuit board.
Peak Input Board Voltage (DC)	The peak input voltage measured by the internal circuit board.
Average Motor Current	The average motor current measured by the unit.
Peak Motor Current	The peak motor current measured by the unit.
Average Internal Temperature	The average internal temperature seen by the unit.
Peak Internal Temperature	The peak internal temperature seen by the unit.
Low Internal Temperature	The lowest internal temperature seen by the unit.

Sample Technical Summary

G3 Technical Summary								
DMS ID Number: 00025 (see page 39)								
Software Part Number:16F821								
Software Version: 0205								
12/27/2010	9:50:51							
Latest Values								
Temp	Voltage							
31C	23.877							
Type	Start Date	Average Board Voltage	Peak Board Voltage	Average Motor Current	Peak Motor Current	Average Internal Temp	Peak Internal Temp	Low Internal Temp
User	12/21/2010	23.877	23.877	0.062	0.062	30C	35C	28C
Factory	9/30/2010	22.804	23.877	1.091	0.362	33C	42C	-10C

Advanced Programming

There are 11 Advanced Programming options. The following Table Identifies each option and when it is used.

Advanced Option	Model	Setting	Format/ Description	Why Use This?
A1	Max	Lockout Code (Optional)	Secures setup modes with PIN	Prevents unauthorized users to adjusting settings.
A2	Max	Low Level Alarm Time	MM:SS (minutes:seconds) sets amount of time between Low Level Warning to Low Level Fault. Default = 3 minutes	To accommodate most lubrication situations, a conservative amount of time is programmed between the low level warning and fault to help protect unit from running dry. If necessary the amount of time the unit runs before stopping due to a low level fault can be adjusted.
A3	Max	Vent Valve Time	MM:SS (minutes:seconds) sets amount of time vent valve stays open after Pump ON Mode. Default = 5 minutes	<ul style="list-style-type: none"> In an injector based system that does not use a sensor for feedback, determines the amount of time the system vents. Vent time can be modified.
A4	Max	Alarm Retry	Sets number of automatic retries after a Cycle or Pressure Alarm. Default = 0	Establishes the number of times the unit automatically retries lubricating after a cycle or pressure alarm to determine if a temporary or false signal can be cleared.
A5	Max	Active Alarm	Changes alarm output behavior. Default = OFF	<p>Uses alarm output to determine if a unit has an alarm AND/OR loses power.</p> <p>The output turns ON when power is applied. It turns OFF when power is lost or an alarm occurs.</p> <p>Normal operation (OFF) will only activate alarm output in an alarm condition when power is on.</p> <p>Can change (set to ON) to activate alarm with power ON and deactivate with power OFF OR warning.</p> <p>Used to manage power outage.</p>
A6	DMS™ Equipped Models	Functional and Technical User Summary Reset	Clears the Functional and Technical User Summaries	Allows user to track lube events from a specific point (reset), i.e. a month to month evaluation.
A7	Max	Constant Alarm Output on Fault	Changes alarm output behavior. Default = OFF	This function changes the behavior of the alarm output in a fault from either toggling once every second or steady on.

Firmware 6.02 and later

A8	Max	4 Digit Hour Off Time	Changes maximum OFF time. Default = OFF	This function changes OFF time from HH:MM to HHHH. It allows a maximum of 9999 hours of OFF time.
A9	Max and "08" option	Toggle Low Level Output on Warning or Fault	Changes Low Level Indication behavior. Default = OFF	This function changes the behavior of the low level output in a warning or fault from either steady on or toggling once per second.

Firmware 6.04 and later for non-DMS models and 07.07 and later for DMS models.

A10	Max	Low Level Reset Upon Power ON	Changes low level fault upon power ON. Default = OFF	This function changes the behavior of the low level fault upon power ON.
A11	Max	Warning OFF through alarm relay	Changes alarm output behavior. Default = OFF	This function changes the behavior of the alarm output in a warning condition to always OFF.

Entering a PIN Code for the First Time

A1 - Setting Up PIN Code

A PIN Code can be programmed into the G3 to protect the settings from inadvertently being changed by unauthorized users.

1. Press the UP ARROW button for 10 seconds.



The LED next to the LOCK ICON on the display lights, indicating you have entered the PIN Mode.



2. The word OFF appears in the display. Press the UP or DOWN ARROW button to change this to ON.



3. Press the ENTER button to enter the PIN Code.



4. The cursor automatically is positioned to entered the first character of the PIN Code. Use the UP and DOWN ARROW buttons to move up and down through the numbers 0-9 until the first number in the PIN code is displayed in the field.



5. Press the ENTER button to set the number. The cursor automatically moves to the next number field.



6. Repeat steps 4 and 5 for each PIN Code prompt field.

7. Press the ENTER button to save the PIN Code and exit Advanced Setup.



Entering Advanced Setup

Press the UP ARROW button for 10 seconds.



If the G3 was previously set up to require a PIN Code, the LED next to the LOCK ICON lights, indicating a PIN Code is required.

1. The cursor is automatically positioned to enter the first character of the PIN Code. Use the UP and DOWN ARROW buttons to move up and down through the numbers 0-9 until the first number in the PIN code is displayed in the field.



2. Press the ENTER button to set the number. The cursor automatically moves to the next number field.



3. Repeat steps 1 and 2 for each PIN Code prompt field.

If the PIN Code you entered is correct, the first editable character on the display will flash.

Selecting Advanced Setup Options

1. Press the UP or DOWN ARROW button to move up or down through Advanced Options A1 - A7.

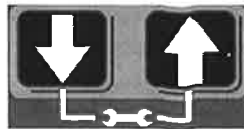

2. Press the ENTER button to set the selection.



A2 - Low Level Alarm Time Pump ON mode only.

Programs the amount of time in MM: SS (minutes and seconds) the pump can run between a Low Level Warning and a Low Level Fault to help protect unit from running dry.

The maximum recommended length of time is 3:00 minutes.

Fault, and Low Level LED illuminate. (Max Model Display shown in illustration below).



FIG. 34

NOTE: When programming a time of less than 10 minutes you **must** program a leading zero in the first number field and press the ENTER button to save the zero selection.

1. To set the time use the UP or DOWN ARROW button to scroll through numerals 0 to 9 until the desired number appears in the first MM (minutes) field.



2. Press the ENTER button to lock in the selection. The next MM number field to the right flashes indicating it is ready for programming.



3. Use the UP or DOWN ARROW button to scroll through numerals 0 to 9 until the desired number appears in the second MM number field.



4. Press the ENTER button to lock in the selection.



The next number field to the right flashes and the LED lights under SS; indicating it is ready to program the seconds fields.

5. Repeat steps 1 - 4 to set the SS (seconds) fields.

6. After pressing the ENTER button to set the last SS field, all the programmed ON Time information is saved.



Unit exits Advanced Programming.

A3 - Vent Valve Time

The Vent Valve Time is the amount of time the vent valve stays open after a cycle is completed.

The recommended Vent Valve Time is 5 minutes.

To bypass the Vent Valve Time enter a value of 00:00.

Vent Valve time must be less than the programmed OFF time (page 37). If it is not set to a value less than the programmed OFF time, the G3 will automatically adjust the time to a value 2 seconds less than the set OFF time.

To set Vent Valve Time:

NOTE:

- The LED next to the clock in the OFF field lights and P1, P2, and P3, indicating the Vent Valve Time is being programmed.

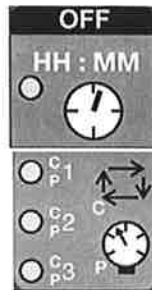

- Time is set as minutes and seconds (MM:SS) only.

- The small flashing LED under the MM indicates you are setting Minutes.



- The first field (left side of display) blinks indicating the device is ready for you to begin programming.



- When programming a time of less than 10 minutes you **must** program a leading zero in the first number field and press the ENTER button to save the zero selection.

- To set the Time use the UP or DOWN ARROW button to scroll through numerals 0 to 5 until the desired number appears in the first minute field.

- Press the ENTER button to lock in the selection. The next minute field to the right flashes indicating it is ready for programming.



- Use the UP or DOWN ARROW button to scroll through numerals 0 to 9 until the desired number appears in the second minute field.



- Press the ENTER button to lock in the selection.



- The next number field to the right flashes and the LED lights under SS; indicating it is ready to program the Seconds fields.



- Repeat steps 1 - 4 to set the MM (seconds) fields.

- After pressing the ENTER button to set the last seconds field, all the programmed Time information is saved.



Unit exits Advanced Programming.

A4 - Alarm Retry

Programs the number of times G3 will automatically retry running a lubrication cycle after a cycle or pressure alarm activates. The default setting is 0. For assistance determining a reasonable number of Alarm Retries to program for your application, contact Graco Customer Service or your local Graco distributor.

1, 2, and 3 and Fault LED's illuminate.



FIG. 35

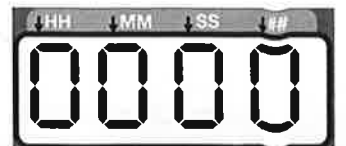

To set the Alarm Retry:

- The default value 0000 appears in the display.



- Press the UP or DOWN ARROW button to move up or down through number 0-9.



3. When the correct number displays, press the ENTER button to set the number. 
4. Repeat 2 - 3 to set the remaining fields.
5. Press the ENTER button to exit Advanced Programming. 

A5 - Active Alarm

Changes the alarm output behavior. Uses output to determine if a fault has occurred.

Fault and ON LED's illuminate.



FIG. 36

1. The default OFF displays.



2. Press the UP or DOWN ARROW button to change OFF to ON on the display to activate alarm condition.



3. Press the ENTER button to exit Advanced Programming. 

A6 - Clearing the Functional and Technical User Summary (DMS™ Models only)

The Pump Summary shows run details since the last time the summary was cleared.



FIG. 37

1. Press the UP or DOWN ARROW button to move through Advanced Options until Advanced Option A6 is displayed.



2. Press the ENTER button.



3. "Data" displays.

data

4. Press the RESET button. "Reset" displays. The summary data is cleared.

RESET

5. Press the RESET or ENTER button to exit.



A7- Constant Alarm Output ON Fault

This function changes the behavior of the alarm output in a fault from either toggling once every second (default) or steady on.

Fault and Warning LEDs Illuminate

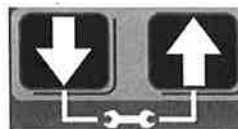

FIG. 38

1. The default OFF is displayed. The alarm output will toggle once a second.



2. Press the UP or DOWN ARROW to change OFF to ON on the display to change the alarm output to be on steady



3. Press the ENTER button to exit Advanced Programming.



A8 - 4 Digit Hour OFF Time

Changes the OFF time from HH:MM to HHHH. Allows for a maximum of 9999 hours of OFF time.

OFF LED illuminates.



FIG. 39

1. The default OFF displays.



2. Press the UP or DOWN ARROW button to change OFF to ON on the display to activate alarm condition.



3. Press the ENTER button to exit Advanced Programming.



A9 - Toggle Low Level Output on Low Level Warning or Fault

This function changes the behavior of the low level output in a warning or fault from either steady on (default) or toggling once every second.

Low Level and Warning LEDs Illuminate

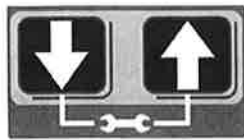

FIG. 40

1. The default OFF is displayed. The alarm output will toggle once a second.



2. Press the UP or DOWN ARROW to change OFF to ON on the display to change the alarm output to be on steady.



3. Press the ENTER button to exit Advanced Programming.



A10 - Low Level Reset Upon Power On. (Models with Firmware 6.03 and later. DMS Models with Firmware 7.07 and later.)

This function changes the behavior of the low level upon pump power on. When A10 is on, a low level fault clears when the pump power is cycled. The pump will revolve 5 revolutions, checking to see if the low level condition is still present. If not, it will self clear and continue. If a low level condition exists during the 5 revolutions, it will go into a low level fault.

Low Level ON LED illuminates (Fig. 41).



FIG. 41

1. The default OFF is displayed. The alarm output will toggle once a second.



2. Press the UP or DOWN ARROW button to change OFF to ON on the display to change the low level reset upon power on.



3. Press the ENTER button.



A11- Warning Off Through Alarm Relay

This function changes the behavior of the alarm output in a warning condition to always off.

Fault and Warning LEDs Illuminate



FIG. 42

1. The default OFF is displayed. The alarm output will turn on during a warning condition.



2. Press the UP or DOWN ARROW to change OFF to ON on the display to change the alarm output to be off during a warning condition.



3. Press the ENTER button to exit Advanced Programming.



Run Mode

Time Control

After setup is complete, the G3 automatically begins to run the OFF Time sequence (FIG. 43).

- The G3 runs the programmed OFF sequence.

(Notice the OFF Time LED on the display lights and the OFF Time counts down on the display.)

- The example shown in FIG. 43 shows an OFF Time of 1 hour and 32 minutes before the lubrication cycle begins.



FIG. 43

- When the OFF Time count reaches zero, the G3 Automatic Lubrication Pump turns the pump on and it runs for the programmed ON Time cycle (FIG. 44).

(Notice the ON Time LED is now illuminated on the display.)

- The example shown in FIG. 44 shows an ON Time of 8 minutes and 42 seconds before the lubrication cycle ends.



FIG. 44

- When the ON Time count reaches zero, the pump shuts off again and the system again runs OFF Time cycle and the OFF Time LED is now again illuminated (FIG. 43).

This sequence repeats itself until the device is reprogrammed or an alarm occurs.

- If power to the pump is lost during a lubrication cycle, when power is restored the pump will resume the cycle with the same amount of time remaining in the cycle as when the power was lost.

Lubrication Mode (Pump ON) Controls

In Max models the Lubrication Mode (Pump ON) can be controlled by either cycle and/or pressure sensors.

If cycle and/or pressure controls have been set to something other than OFF the display will alternate between cycles (C1, C2, C3) and/or active sensors (P1, P2, P3) and Backup Time.

If cycle or pressure controls have been set to OFF then the Lubrication Mode (Pump ON) will be controlled by On Time (see Time Control, page 54).

With cycle and/or pressure controls set, the lubrication cycle (Pump ON) is ended by meeting *all* required cycle and/or pressure settings.

Cycle Control

- A set number of triggered counts in a cycle based system (C1). Typically a proximity switch connected to a divider valve.
- The LED next to the appropriate sensor (C/P1, C/P2, C/P3) illuminates.
- The display indicates the sensor (C1, C2, C3) and the remaining cycles for that sensor (FIG. 45).

The example shown in FIG. 45 shows sensor C1 with 5 cycles remaining.



FIG. 45

Pressure Control

- A single triggered count in a **pressure based system** (P1). Typically a pressure switch on the end of a line of injectors.
- The LED next to the appropriate sensor (C/P1, C/P2, C/P3) illuminates (FIG. 46 and FIG. 47).
- The display indicates the sensor (P1, P2, P3) and whether the pressure switch for that sensor has been triggered or not.

- 01 = pressure switch has not been triggered
- 00 = pressure switch is triggered.

The example shown in FIG. 46 shows sensor P1 with a pressure switch that has been triggered.

FIG. 47 (page 56) shows sensor P2 with a pressure switch that has NOT been triggered.



FIG. 46



FIG. 47

Backup Time

- In both Cycle and Pressure modes a Backup Time (maximum run time) has been set.
- The LED(s) next to all programmed sensors (C/P1, C/P2, C/P3) illuminate.
- The display shows time remaining until a fault.

The example shown in FIG. 48 shows 14 minutes and 33 seconds left until the fault occurs.

- If all cycle and/or pressure requirements are met the unit exits the lubrication cycle (Pump ON) and enter the rest cycle (Pump OFF).



FIG. 48

Rest Mode (Pump OFF) Controls

In Max models the Rest Mode (Pump OFF) is controlled by machine counts.

If the Machine Count is set to a value greater than **0000** and the Backup Time option **is activated**, the display will alternate between Machine Counts and Backup Time.

If Machine Count has been set to a value greater than **0000** and the Backup Time option is **NOT activated**, the display will only show the number of Machines Counts remaining.

With machine count set, the Rest Cycle (Pump OFF) is ended when the machine count reaches zero (0000).

Machine Count

- A set number of triggered counts.
- The LED next to 1-2-3 illuminates (FIG. 49).
- The display indicates the number of machine counts remaining.

The example shown in FIG. 49 shows the remaining number of machine counts is 0045.



FIG. 49

Backup Time

In Machine Count mode, if a Backup Time (maximum rest time) has been set:

- The LED next to 1-2-3 illuminates (FIG. 50).
- The display shows the amount of time remaining till a fault or lubrication mode (pump ON).

The example shown in FIG. 50 shows 4 hours and 17 minutes remaining until a fault or lubrication mode (pump ON) occurs.

- If the Machine Count requirements are met the unit will exit the Rest Mode (Pump OFF) and enter the Lubrication Mode (Pump ON).



FIG. 50

OFF Time

In Max models if the Machine Count is set to **0000** then Reset Mode (Pump OFF) is controlled with OFF Time (see Time Control, page 54).

Additional Controls

Venting

In Max models a Vent Time can be set using the Advanced Programming mode (page 48). This is typically done in a Pressure Based System (P1) to allow injectors to reset.

- Unit vents for a set amount of time (not displayed).
- The LED's next to C/P1, C/P2, C/P3 flash while unit is venting.
- If Machine Count is set, the display will alternate between machine counts remaining and backup time (Max Model Rest Mode, page 56).
- If Machine Count has been set the LED next to 1-2-3 illuminates (FIG. 49, page 57).
- If Machine Count has not been set the display shows OFF Time (See Time Control, page 54).
- If Machine Count has not been set the LED next to the clock in the OFF field illuminates (See Time Control, page 54).

Prelube / Prelube Delay

In all models a power OFF/ON cycle can be controlled with the Prelube and Prelube Delay functions.

Prelube

The Prelube function has been selected. Prelube delay is set to 00:00:

- Power to the unit cycles OFF then ON.
- Unit immediately begins a lubrication cycle.
- Max Model - display shows Cycle/Pressure/Backup Time (See Max Model Lubrication Mode Controls, page 55).

Prelube Delay

The Prelube function has been selected. Prelube delay is set to something other than 00:00:

- Power to the unit cycles OFF then ON.
- Unit immediately begins the Prelube Delay count down until the lubrication cycle begins.
- The LED next to the clock in the OFF field is illuminated (FIG. 51).
- The Prelube LED lights (FIG. 51).

- The display shows time remaining until lubrication cycle begins. The example shown in FIG. 51 shows 8 minutes and 14 seconds left until a lubrication cycle begins.



FIG. 51

Manual Run Cycle



To run an extra (non-programmed) lubrication cycle, push the Manual Start button.

NOTE: Manual Run option is not available while unit is in Vent Mode.

Alarms: Firmware Versions 6.01 and Below

Any time a Fault / Warning occurs, a combination of LED's will illuminate to notify you there is a problem and help identify the kind of Fault / Warning has occurred.

- Faults and Warnings will not automatically clear.
- To clear an fault, press and hold the RESET button on the display button pad for 3 seconds.



- To clear a warning press and immediately release the RESET button.











Fault / Warning Scenarios



The following pages describe the most likely fault / warnings you could receive.



Alarm Type	What it Looks Like	What it Indicates	Solution
Low Level Warning		<p>Level of lubricant in reservoir is low and additional lubricant needs to be added.</p> <p>Unit continues to operate as normal for a limited period of time until a low level alarm is triggered.</p>	<p>Add lubricant to reservoir.</p> <p>After lubricant is added, press the RESET button to clear the warning.</p>



<p>Low Level Fault</p>		<p>Level of lubricant in reservoir is low and additional lubricant needs to be added.</p> <p>Unit stops pumping and displays amount of accumulated time since the alarm was triggered.</p>	<p>Add lubricant to reservoir.</p> <p>After lubricant is added press and hold the  button to clear fault.</p> <p>If repriming pump is required, the low level alarm time should be decreased. See A-2: Advanced Programming, Low Level Alarm Time page 48.</p>
<p>Cycle / Pressure Warning</p>		<p>System fails to relieve pressure or a lubrication cycle was not completed in the user-defined amount of time.</p> <p>Unit will continue to operate for the number of lubrication cycles set by the warning retry parameter (see Advanced Programming, page 46).</p> <p>If the warning condition clears itself on the next automatic lubrication cycle, the warning is cleared and the unit continues normal operation.</p>	<p>Examine system to determine if you have a plugged or broken line or other component failure, i.e., divider valve, injector.</p> <p>Press the  button to clear warning.</p>

<p>Cycle / Pressure Fault</p>	 <p>The control panel displays a fault. The top display shows 'HH MM SS #'. Below it are 'ON' and 'OFF' sections with 'MM:SS' and 'HH:MM' respectively. There are three pressure sensors labeled 'C1', 'C2', and 'C3'. A digital display shows '123'. At the bottom, there are four buttons: a crossed-out circle, a downward arrow, an upward arrow, and a crossed-out leaf.</p>	<p>In pressure mode indicates that unit is over pressurized or a lubrication cycle was not completed in the user-defined amount of time.</p> <p>In cycle mode indicates that a cycle was not completed in the user-defined amount of time.</p> <p>LED corresponding to the affected sensor input blinks.</p> <p>Could be more than one sensor alarm at the same time.</p>	<p>Examine system to determine if you have a plugged or broken line or other component failure, i.e., divider valve, injector.</p> <p>Press and hold the RESET button to clear fault.</p> 
<p>Machine Count Fault</p>	 <p>The control panel displays a fault. The top display shows 'HH MM SS #'. Below it are 'ON' and 'OFF' sections with 'MM:SS' and 'HH:MM' respectively. There are three pressure sensors labeled 'C1', 'C2', and 'C3'. A digital display shows '123'. At the bottom, there are four buttons: a crossed-out circle, a downward arrow, an upward arrow, and a crossed-out leaf.</p>	<p>Unit has not received the correct number of machine counts in the user defined Backup Time.</p>	<p>Examine system to determine if the machine sensor is operating properly.</p> <p>Press and hold the RESET button to clear fault.</p> 

<p>System Fault</p>	 <p>The control panel features a blank LCD display at the top. Below it are two columns of controls: 'ON' with 'MM : SS' and 'OFF' with 'HH : MM'. There are three pressure indicators (C_{P1}, C_{P2}, C_{P3}) and a digital display showing '123'. The bottom row contains four directional buttons: left, down, up, and right.</p>	<p>An internal fault has occurred.</p>	<p>Contact Graco Customer Service.</p>
<p>Motor Current Warning</p>	 <p>The control panel is identical to the one above, but the LCD display now shows '4.15 A'.</p>	<p>The measured motor current is above the recommended operating maximum value. Continued use at excessive motor currents could reduce life or cause permanent damage.</p>	<p>Examine system to make sure it is operating correctly. A blocked line could create excessive motor current</p> <p>Examine pump to ensure that it is rotating properly.</p> <p>If necessary, contact Graco Customer Service.</p>

<p>Temperature Warning</p>		<p>The internal temperature of the unit is out of its recommended operating range.</p> <p>Use of the unit outside of the recommended temperature range could cause degraded system performance and possible damage.</p>	<p>Ensure the unit is used in the correct operating environment for the specific temperature: -13° F to 158° F (-25° C to 70°C).</p> <p>If necessary contact Graco Customer Service.</p>
<p>USB Error</p>		<p>An error occurred during a DMS operation.</p>	<p>Read the Troubleshooting section of this manual (page 71) for error numbers and fault descriptions.</p>

Alarms: Firmware Versions 6.02 and Above



Any time a Fault / Warning occurs, a combination of LED's will illuminate to notify you there is a problem and help identify the kind of Fault / Warning has occurred. An error message will display and flash every 2 seconds for an alarm, temperature or current warning and every 10 seconds for all other types of warnings.





- Faults will not automatically clear.
- To clear an fault, press and hold the RESET button on the display button pad for 3 seconds.
- To clear a warning press and immediately release the RESET button.







Fault / Warning Scenarios



The following pages describe the most likely fault / warnings you could receive.



Alarm Type	What it Looks Like	What it Indicates	Solution
Low Level Warning		<p>Level of lubricant in reservoir is low and additional lubricant needs to be added.</p> <p>Unit continues to operate as normal for a limited period of time until a low level alarm is triggered or until the reservoir is filled and 30 seconds has passed at which time the warning will self-clear.</p>	<p>Add lubricant to reservoir.</p> <p>After lubricant is added, press the RESET button to clear the warning.</p> 

<p>Low Level Fault</p>		<p>Level of lubricant in reservoir is low and additional lubricant needs to be added.</p> <p>Unit stops pumping and displays amount of accumulated time since the alarm was triggered.</p>	<p>Add lubricant to reservoir.</p> <p>After lubricant is added press and hold the RESET button to clear fault.</p> <p>If repriming pump is required, the low level alarm time should be decreased. See A-2: Advanced Programming, Low Level Alarm Time page 48.</p> 
<p>Cycle Warning</p>		<p>A lubrication cycle was not completed in the user-defined amount of time.</p> <p>Unit will continue to operate for the number of lubrication cycles set by the warning retry parameter (see Advanced Programming, page 46).</p> <p>If the warning condition clears itself on the next automatic lubrication cycle, the warning is cleared and the unit continues normal operation.</p>	<p>Examine system to determine if you have a plugged or broken line or other component failure, i.e., divider valve, injector.</p> <p>Press the RESET button to clear warning.</p> 

<p>Pressure Warning</p>	<p>The control panel displays 'Er:Pr' on the LCD. The 'ON' section shows 'MM:SS' with a pressure gauge icon. The 'OFF' section shows 'HH:MM' with a pressure gauge icon. Below these are three sensor input indicators labeled 'C P1', 'C P2', and 'C P3'. A numeric keypad shows '123'. The bottom row contains four buttons: a crossed-out square, a downward arrow, an upward arrow, and a square with a diagonal line and a plus sign.</p>	<p>System fails to relieve pressure in the user-defined amount of time.</p> <p>Unit will continue to operate for the number of lubrication cycles set by the warning retry parameter (see Advanced Programming, page 46).</p> <p>If the warning condition clears itself on the next automatic lubrication cycle, the warning is cleared and the unit continues normal operation.</p>	<p>Examine system to determine if you have a plugged or broken line or other component failure, i.e., divider valve, injector.</p> <p>Press the RESET button to clear warning.</p> <p>The RESET button is represented by a square icon with a left-pointing arrow and a crossed-out circle.</p>
<p>Cycle Fault</p>	<p>The control panel displays 'Er:C4' on the LCD. The 'ON' section shows 'MM:SS' with a pressure gauge icon. The 'OFF' section shows 'HH:MM' with a pressure gauge icon. Below these are three sensor input indicators labeled 'C P1', 'C P2', and 'C P3'. A numeric keypad shows '123'. The bottom row contains four buttons: a crossed-out square, a downward arrow, an upward arrow, and a square with a diagonal line and a plus sign.</p>	<p>In cycle mode indicates that a cycle was not completed in the user-defined amount of time.</p> <p>LED corresponding to the affected sensor input blinks.</p> <p>Could be more than one sensor alarm at the same time.</p>	<p>Examine system to determine if you have a plugged or broken line or other component failure, i.e., divider valve, injector.</p> <p>Press and hold the RESET button to clear fault.</p> <p>The RESET button is represented by a square icon with a left-pointing arrow and a crossed-out circle.</p>

<p>Pressure Fault</p>		<p>In pressure mode indicates that unit is over pressurized or a lubrication cycle was not completed in the user-defined amount of time.</p> <p>LED corresponding to the affected sensor input blinks.</p> <p>Could be more than one sensor alarm at the same time.</p>	<p>Examine system to determine if you have a plugged or broken line or other component failure, i.e., divider valve, injector.</p> <p>Press and hold the RESET button to clear fault.</p> 
<p>Machine Count Warning</p>		<p>If the warning condition clears itself on the next automatic lubrication cycle, the warning is cleared and the unit continues normal operation.</p>	<p>Examine system to determine if the machine sensor is operating properly.</p> <p>Press and hold the RESET button to clear warning.</p> 

<p>Machine Count Fault</p>		<p>Unit has not received the correct number of machine counts in the user defined Backup Time.</p>	<p>Examine system to determine if the machine sensor is operating properly.</p> <p>Press and hold the RESET button to clear fault.</p> 
<p>System Fault</p>		<p>An internal fault has occurred.</p>	<p>Contact Graco Customer Service.</p>

<p>Motor Current Warning</p>		<p>The measured motor current is above the recommended operating maximum value. Continued use at excessive motor currents could reduce life or cause permanent damage.</p> <p>Warning will self-clear any time after 15 seconds On Time start if the system correction is made.</p>	<p>Examine system to make sure it is operating correctly. A blocked line could create excessive motor current</p> <p>Examine pump to ensure that it is rotating properly.</p> <p>If necessary, contact Graco Customer Service.</p>
<p>Temperature Warning</p>		<p>The internal temperature of the unit is out of its recommended operating range.</p> <p>Use of the unit outside of the recommended temperature range could cause degraded system performance and possible damage.</p>	<p>Ensure the unit is used in the correct operating environment for the specific temperature: -13° F to 158° F (-25° C to 70°C).</p> <p>If necessary contact Graco Customer Service.</p>

<p>USB Error</p>		<p>An error occurred during a DMS operation.</p>	<p>Read the Troubleshooting section of this manual (page 71) for error numbers and fault descriptions.</p>
-------------------------	---	--	--

Troubleshooting



Problem	Cause	Solution
Unit does not power on	Incorrect/loose wiring	Refer to Installation instructions, page 8.
Unit does not power on (DC models only)	Tripped external fuse due to internal component failure	Contact Graco Customer Service.
	Tripped external fuse due to pumping non-cold weather lubricant in cold weather -13°F (-25°C)	Replace lubricant with pumpable lubricant, rated for environmental conditions and application. Replace fuse.
Unit does not power on (AC models only)	Tripped internal power supply fuse due to power supply failure	Contact Graco Customer Service.
Can't set desired ON/OFF times	Maximum duty cycle is 33% (2 minutes OFF for each minute ON)	Adhere to allowable duty cycle. Contact Graco Customer Support if other duty cycles are required for application.
Unit is not operating based on the time that was programmed	Time entered was misinterpreted as MM:SS instead of HH:MM (or visa versa)	Verify the unit was programmed as intended, referencing programming instructions. Note the dot designation for hours, minutes, seconds on the top row of the display.
Lubricant leaks past seal located on the bottom of the reservoir	Reservoir retaining tabs are cracked or broken	Replace reservoir.
	Reservoir is being pressurized during filling	Ensure vent hole is not plugged. If problem persists, contact Graco Customer Service or your local Graco distributor for assistance.
Unit not pumping during ON cycle, but controller lights and functions	Failed motor	Replace unit.
Follower plate is not going down	Air is trapped in the reservoir between the follower plate and lubricant	Add grease following Loading Grease instructions, page 22. Ensure air is purged.
Pump takes several minutes before it begins pumping at the highest pump volume setting (no stroke adjust spacers installed)	Pumping non-cold weather lubricant in cold weather -13°F (-25°C)	Add 1 stroke adjust spacer and adjust lube cycle time to accommodate the difference in pump volume per stroke.
Dim display, unit is not operating	Tripped internal, resettable fuse due to internal component failure or sensor short circuit condition	Verify sensor and manual run inputs have not created a short circuit condition. Cycle power.
Unit indicates a cycle or pressure alarm before the lubrication cycle could complete	The ON Time was not entered correctly	Refer to programming ON Time, pages 32 and 55.

Troubleshooting



Problem	Cause	Solution
In an Injector System without sensor feedback, unit does not vent properly	Vent valve time needs to be configured	Refer to Advanced Programming to set ON Time, page 46.
Display acts erratically	Faulty cycle/pressure wiring connection to unit	Unplug cycle/pressure cables from G3. Plug cables in one at a time to identify the faulty connection.
USB Error 00	Flash drive was removed during operation	Keep the flash drive plugged in until the unit has completed the operation.
USB Error 07	Flash drive unable to mount (initialize)	<ul style="list-style-type: none"> • Unplug the flash drive and re-install. • Cycle power and re-install the flash drive. • Retry using a different flash drive. • Verify format is FAT32 file system. If not, may need to reformat flash drive or find a different drive that has this file system. <p>If any of the above do not rectify the error, contact Graco Customer Service.</p>
USB Error 11	Pump program setting file not found	Verify that the pump program setting folder structure and file are stored correctly on the flash drive. See Storing Pump Program Settings to the Flash Drive, page 38 for instructions.
USB Error 12	Pump program settings directory not found.	Verify that the pump program setting folder structure and file are stored correctly on the flash drive. See Storing Pump Program Settings to the Flash Drive, page 38 for instructions.
USB Error 13	Bad pump program settings file	The pump programs settings file is corrupt. Restore file to the flash drive. See Storing Pump Program Settings to the Flash Drive, page 38 for instructions.
All other USB errors		<p>The following operations can be attempted if another error occurs using the USB.</p> <ul style="list-style-type: none"> • Unplug the flash drive and re-install. • Cycle power and re-install the flash drive. • Retry using a different flash drive. <p>If any of the above do not rectify the error, contact Graco Customer Service.</p>

Maintenance

Frequency	Component	Required Maintenance
Daily and at refill	Zerk Fittings	Keep all fittings clean using a clean dry cloth. Dirt and/or debris can damage pump and/or lubrication system.
Daily	G3 Pump Unit and Reservoir	Keep pump unit and reservoir clean using a clean dry cloth.
Daily	Display	Keep display clean using a clean dry cloth.
Monthly	External Wiring Harness	Verify external harnesses are secure.

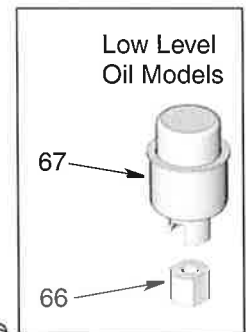
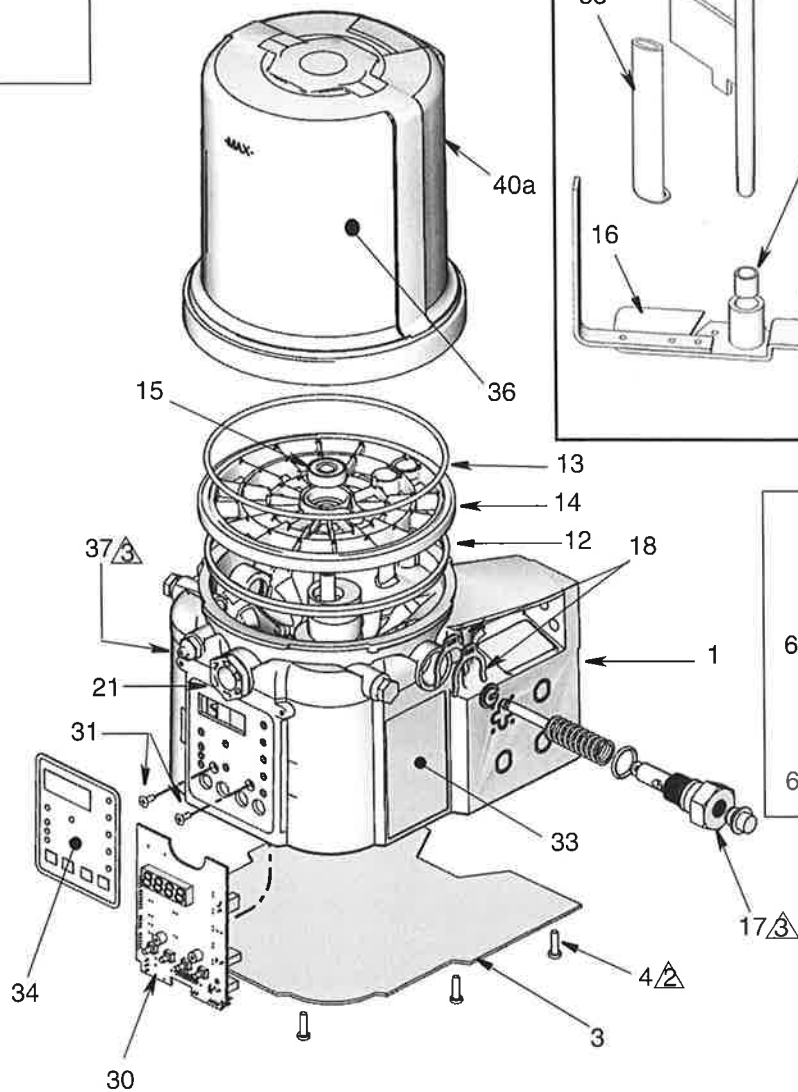
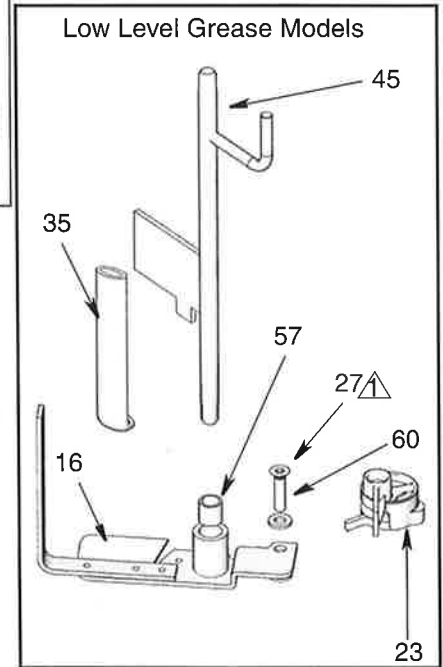
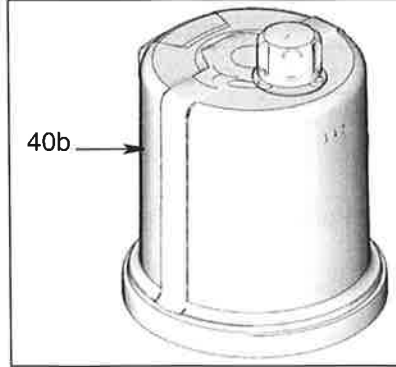
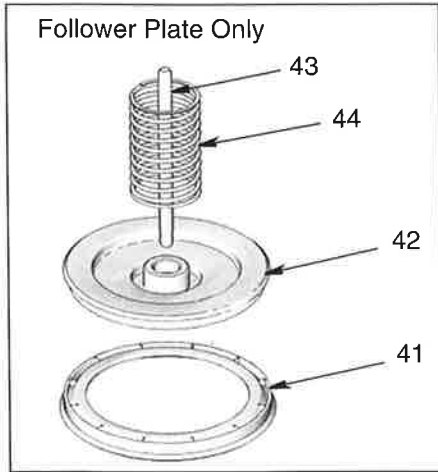
Parts - 2 Liter Models



-  Torque to 4 in. lbs (0.45 N.m)
-  Torque to 30 in. lbs (3.4 N.m)
-  Torque to 50 in. lbs (5.6 N.m)

Parts - 4 Liter and Larger Models

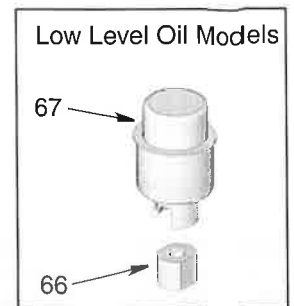
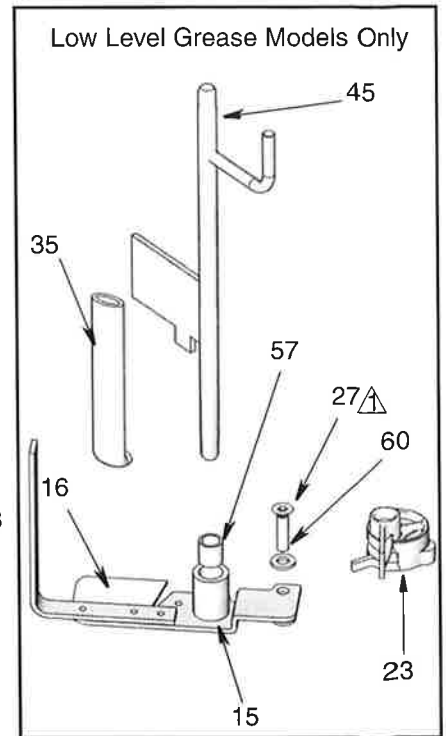
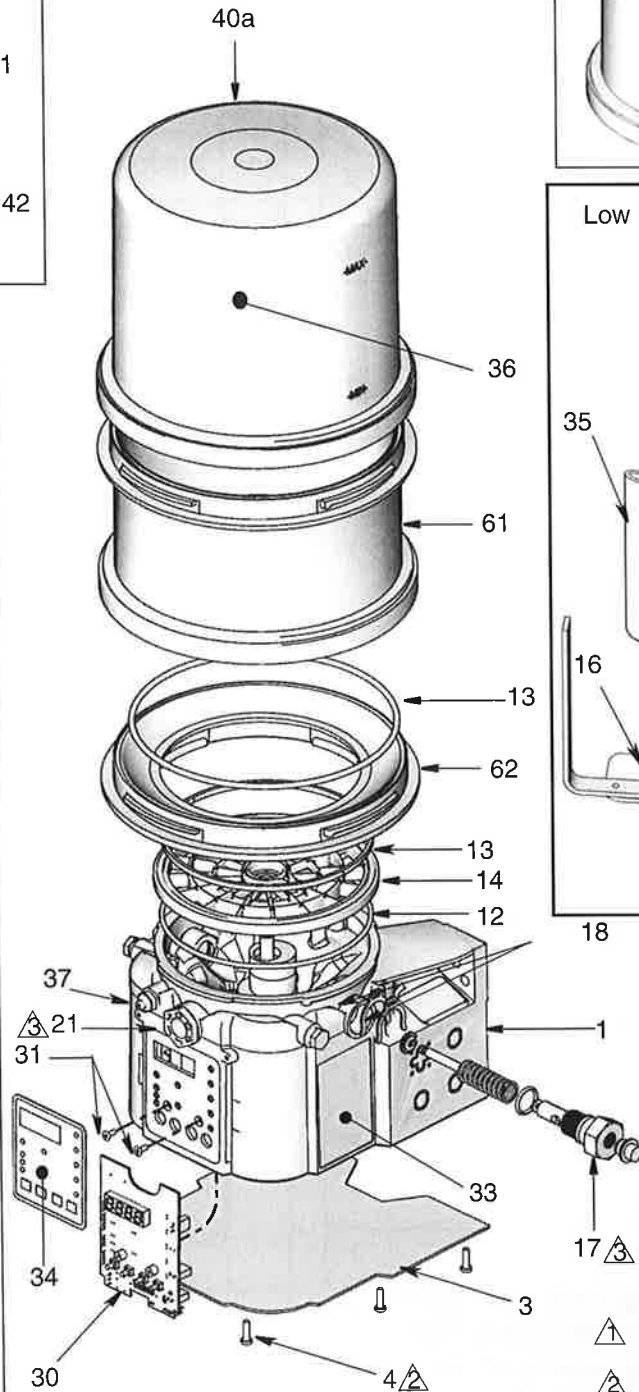
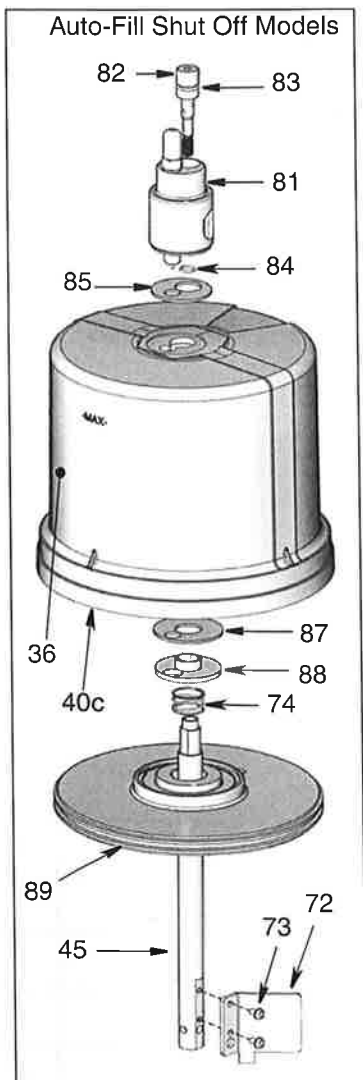
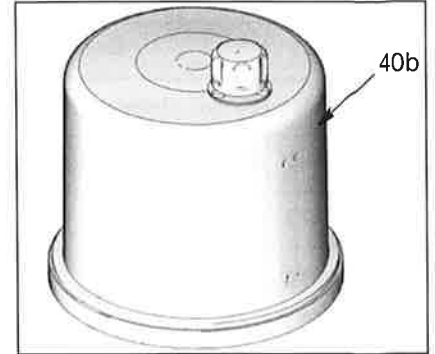
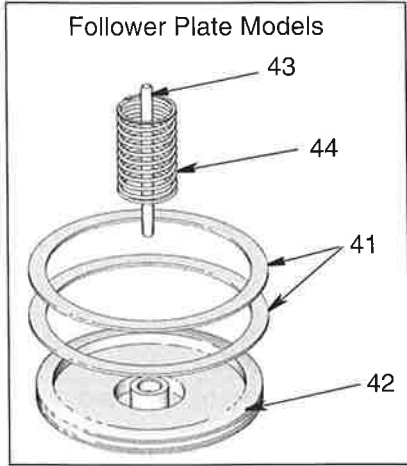

- Torque to 4 in. lbs (0.45 N.m)
- Torque to 30 in. lbs (3.4 N.m)
- Torque to 50 in. lbs (5.6 N.m)

Parts

Ref	Part	Description	Qty
1		BASE, three pump housing	1
3	278142	COVER, bottom, with seal	1
4	115477	SCREW, mach, torx pan hd	9
12	127079	RECT-RING, included in Kit 571042, 571069, 571179	1
13	124396	O-RING, 258, included in Kit 571042, 571044, 571045, 571069, 571179	2
14		PLATE, ricer	1
15		BEARING, ball	1
16		PADDLE, stirring, 2 Liter models without follower plate, included in Kit 571044	1
		PADDLE, stirring, 4 Liter models and larger without follower plate	1
		PADDLE, stirring, 2 Liter models with follower plate, included in Kit 571045	1
		PADDLE, stirring, 4Liter models and larger with follower plate	1
17		PUMP, element, included in Kit 571041	1
18	16F368	SPACER, stroke adjust, included in Kit 571041	2
21	278145	PLUG, pump, 3/4-16	2
23	278136	PADDLE, low level	1
27	123025	SCREW, M6	1
30	258697	BOARD, circuit, Max, models †★	1
	†★ 262463	BOARD, circuit, Max, DMS™ models	1
31	119228	SCREW, machine, flat head	2
33	16A579	LABEL, safety	1
34	16A073	LABEL, overlay	1
35		WIPER, stirring, models without follower plate, included in Kit 571044	1
		WIPER, stirring, models with follower plate, included in Kit 571045	1

Ref	Part	Description	Qty
36		LABEL, brand	1
37	123741	FITTING, Zerk, grease	1
40a	24E984	RESERVOIR, 2 liter, grease, included in Kit 571042, 571069	1
40b	16G021	RESERVOIR, 2 liter, oil, included in Kit 571179	1
40a	24B702	RESERVOIR, 4 liter, grease, included in Kit 571183	1
40b	16G020	RESERVOIR, 4 Liter, oil, included in kit 571182	1
40c	17F484	RESERVOIR, 4 Liter, G3 AF50	1
41	278139	SEAL, follower plate, 2 liter models	1
	16F472	SEAL, follower plate, 4 liter models	2
42		PLATE, follower	1
43		ROD, follower plate	1
44		SPRING, compression	1
45†	24D838	BAFFLE, low level, 2 liter models	1
†	24E246	BAFFLE, low level, 4 liter models	1
†	24F836	BAFFLE, low level, 8 liter models	1
†	24F923	BAFFLE, low level, 12 liter models	1
†	24F924	BAFFLE, low level, 16 liter models	1
57	117156	BEARING, sleeve	1
58▲	196548	LABEL	1
60	16D984	WASHER, low level models	2
61		RESERVOIR, mid-section (see quantity by size / model below)	
		8 Liter models	1
		12 Liter models	2
		16 Liter models	3
62		ADAPTER, reservoir	1
66	126417	NUT, oil	1
67	24N806	FLOAT, oil	1

Ref	Part	Description	Qty
72		PLATE, baffle, low level	1
73		SCREW, machine	2
74		SPRING, plate, valve, reset	1
81		VALVE, AFSO	1
82		BOLT, mounting	1
83		PACKING, o-ring	1
84		PACKING, o-ring	1
85		SEAL, upper, reservoir	1
87		SEAL, lower, reservoir	1
88		SPACER, seal, base	1
89		PLATE, valve	1
200	127783	CABLE, 15 ft (4.5 m), SOOW w/7pos, 3 pin, 90 deg	1
	127780	CABLE, 15 ft (4.5 m), SOOW w/7 pos, 5 pin, 90 deg	1
	127781	CABLE, 20 ft (6.1 m), SOOW, w/7 pos, 5 pin, 90 deg	1
	127782	CABLE, 30 ft (9.1m) SOOW, w/7 pos, 5 pin, 90 deg	
	16U790	CABLE, DIN, bare)	1
201	124300	CABLE, M12, 15 ft., 4 wire, straight male to flying leads	1
	124333	CABLE, M12, 15 ft., 4 wire, straight male to female	1
202	124301	CONNECTOR, Eurofast, fem, straight, 4Pin	1
	124594	CONNECTOR, Eurofast, 4 Pin	1
	124595	CONNECTOR, Eurofast, 5 Pin	1

▲ Replacement Danger and Warning labels, tags and cards are available at no cost.

❖ Also order Ref 27, Part No. 123025 and Ref 60, Part No. 16D984

‡★ Also order Ref 31, Part No. 119228 and Ref 34, Part No. 16A073

† Also order Ref. 57, Part No. 117156 when ordering this part.

Pressure Relief Valves

Important Information regarding Pressure Relief Valve 16C807.

◆ **Pressure Relief Valve 16C807 can only be used on the G3 Pump.** It is not intended for use with any other products.

The pressure relief valve uses a pressure adjustment screw (a) to set the pressure release point. **It is not intended as a way to relieve pressure during normal operation**, but as a protective measure in the event there is an unintended pressure increase in the system. Do not use this pressure relief valve as a means of relieving pressure in day-to-day, normal cycle operation.

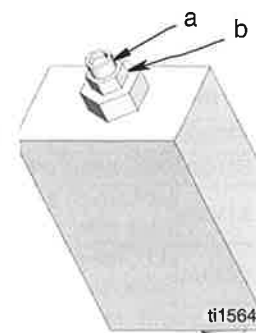

a = adjustment screw
b = locking nut

The pressure adjustment screw will require periodic adjustments. Whenever the valve is set/adjusted (after the set point is found) it is important to ensure that the valve is not bottomed out and there is at least 1/2 turn of adjustment remaining. This is determined by turning the screw (a) 1/2 turn and then back turning it out again.

NOTE: Turning adjustment screw (a) clockwise increases pressure.

Part	Description	Qty
16C807◆	VALVE, pressure relief, 500-3500 psi (3.44 MPa, 34.4 bar - 24.1 MPa, 241 bar), Set pressure 3000 psi ± 10% (20.68 MPa, 206.8 bar ± 10%) Included in Kit 571028	1
563156	VALVE, pressure relief, 750 psi (5.17 MPa, 51.71 bar)	1
563157	VALVE, pressure relief, 1000 psi (6.89 MPa, 68.95 bar)	1
563158	VALVE, pressure relief, 1500 psi (10.34 MPa, 103.42 bar)	1
563159	VALVE, pressure relief, 2000 psi (13.78 MPa, 137.89 bar)	1
563160	VALVE, pressure relief, 2500 psi (17.23 MPa, 172.36 bar)	1
563161	VALVE, pressure relief, 3000 psi (20.68 MPa, 206.84 bar)	1
563190	VALVE, pressure relief, 5500 psi (37.92 MPa, 379.21 bar)	1

Parts

Fuses

Part	Description	Qty
571039	FUSE, 12 volt DC	1
571040	FUSE, 24 volt DC	1

Installation and Repair Kits

Kit No.	Description	Manual Number
571026	KIT, output union, 3 pump	3A0523
571063	KIT, output union, 2 pump	
571028	KIT, return to reservoir NPT, includes pressure relief valve 16C807	3A0525
571071	KIT, return to reservoir BSPP, includes pressure relief valve 16C807	
571030	KIT, remote manual run, 12 volt DC	3A0528
571031	KIT, remote manual run, 24 volt DC	
571032	KIT, remote manual run, 12 volt DC, with cable	
571033	KIT, remote manual run, 24 volt DC with cable	
571036	KIT, cover with "G" label	NA
571041	KIT, pump element, includes Ref 17, 18, 33	3A0533
571042	KIT, repair, 2 liter reservoir, includes Ref 13, 36, 40	3A0534
571069	KIT, repair, 2 liter reservoir, for models with follower plate, includes Ref 13, 36, 40	
571044	KIT, replacement, paddle, 2 liter, for models without follower plate, includes Ref 13, 16, 35, 57	3A0535
571045	KIT, replacement, paddle, 2 liter, for models with follower plate, includes Ref 13, 16, 35, 40a, 42, 57	
571046	KIT, replacement, paddle, 4-16 liter, for models without follower plate, includes Ref 13, 16, 35, 57	
571047	KIT, replacement, paddle, 4 liter, for models with follower plate, includes Ref 13, 16, 35, 57	
571058	KIT, output adapter, NPT	3A0522
571070	KIT, output, adapter, BSPP	
571060	KIT, fill, zerk, leakproof	NA
571179	KIT, repair, reservoir oil, 2 liter models, includes Ref 13, 36, 40b	3A0534
571182	KIT, repair, reservoir, oil 4 liter models, includes Ref 13, 36, 40b	
571183	KIT, repair, reservoir, grease, 4 liter models, includes Ref 13, 36, 40b	
127685	RING, fixing for CPC connector	NA

Technical Data

Pump Output Pressure	5100 psi (35.1 MPa, 351.6 bar)
Fill Inlet Pressure	5000 psi (34.4 MPa, 344.7 bar)
Power	
100-240 VAC	88 - 264 VAC; 0.8 A current, 90 VA Power, 47/63 Hz, Single phase, inrush/locked rotor, max 40A (1ms)
12 VDC	9 - 16 VDC; 5 A current, 60 W, inrush/locked rotor 12 A
24 VDC	18 - 32 VDC; 2.5 A current, 60 W, inrush/locked rotor 6 A
Outputs - Alarm Relay	
Rated Load	Resistive: 0.4 A at 125 VAC, 2 A at 30 VDC Inductive: 0.2 A at 125 VAC, 1 A at 30 VDC
Max Operation Voltage	Resistive: 250 VAC, 220 VAC Inductive: 250 VAC, 220 VDC
Max Operating Current	Resistive: 3 A (AC), 3A (DC) Inductive: 1.5 A (AC), 1.5 A (DC)
Max Switching Capacity	Resistive: 50 VA, 60 W Inductive: 25 VA, 30 W
Min Permissible Load	Resistive: 10 μ A, 10m VDC Inductive: 10 μ A, 10m VDC
Outputs - Vent Valve	
Required Vent Valve Type	Normally closed
Output Voltage	
100/240 VAC	24 VDC
12 VDC	Input Voltage
24 VDC	Input Voltage
Max Operating Current	2 A
Max Operating Power	48 W
Inputs - Cycle Pressure, 1, 2, 3, Machine Count	
Required Switch Type	Normally open (sink, source, or dry contact)
Sensor Voltage	
100/240 VAC	24 VDC
12 VDC	Input Voltage
24 VDC	Input Voltage
Load Current	
100/240 VAC	22mA @ 24 VDC
12 VDC	11mA @ 12 VDC
24 VDC	22mA @ 24 VDC
Maximum Residual Voltage	
100/240 VAC	4 V
12 VDC	2 V
24 VDC	4 V
Maximum Off Current	
100/240 VAC	1.5 mA
12 VDC	1 mA
24 VDC	1.5 mA
Input Impedance	1.1 K
Response Time	60 ms
Cycle Rate	8.0 Hz (50% duty cycle)

Technical Data

Fluid

Grease Models

Grease NLGI 000 - #2

Oil Models

At least 40 cSt oil.

Pumps

Up to 3

Pump Output

0.12 in.³ (2 cm³) / minute per outlet - 2 spacers

0.18 in.³ (3 cm³) / minute per outlet - 1 spacer

0.25 in.³ (4 cm³) / minute per outlet - 0 spacers

Pump Outlet

1/4-18 NPSF. Mates with 1/4-18 NPT male fittings

Reservoir Size

2, 4, 8, 12, 16 Liters

IP Rating

IP69K

Sensor Inputs

3 (any of pressure or cycle)

1 (machine count)

Ambient Temps

-40°F - 158°F (-40°C to 70°C)

Weight (Dry - includes power cord and plug)

Without follower plate

13.3 lbs (6.03 kg)

With follower plate

14.2 lbs (6.44 kg)

Wetted Parts

nylon 6/6 (PA), amorphous polyamide, zinc plated steel, carbon steel, alloy steel, stainless steel, nitrile rubber (buna-N), bronze, nickel plated alnico, chemically lubricated acetal, aluminum, PTFE

Sound Data

<60 dB

Dimensions

Model	Height		Width		Depth	
	Inches	cm	Inches	cm	Inches	cm
2L	13.25	33.65	8.00	20.32	9.00	22.86
4L	14.50	36.83	9.25	23.50	10.00	25.40
8L	18.50	47.00	9.25	23.50	10.00	25.40
12L	23.00	58.42	9.25	23.50	10.00	25.40
16L	27.50	69.85	9.25	23.50	10.00	25.40

Mounting Pattern

(For correct mounting configuration, choose either Option 1 or Option 2). See P/N 126916 template.

Option 1

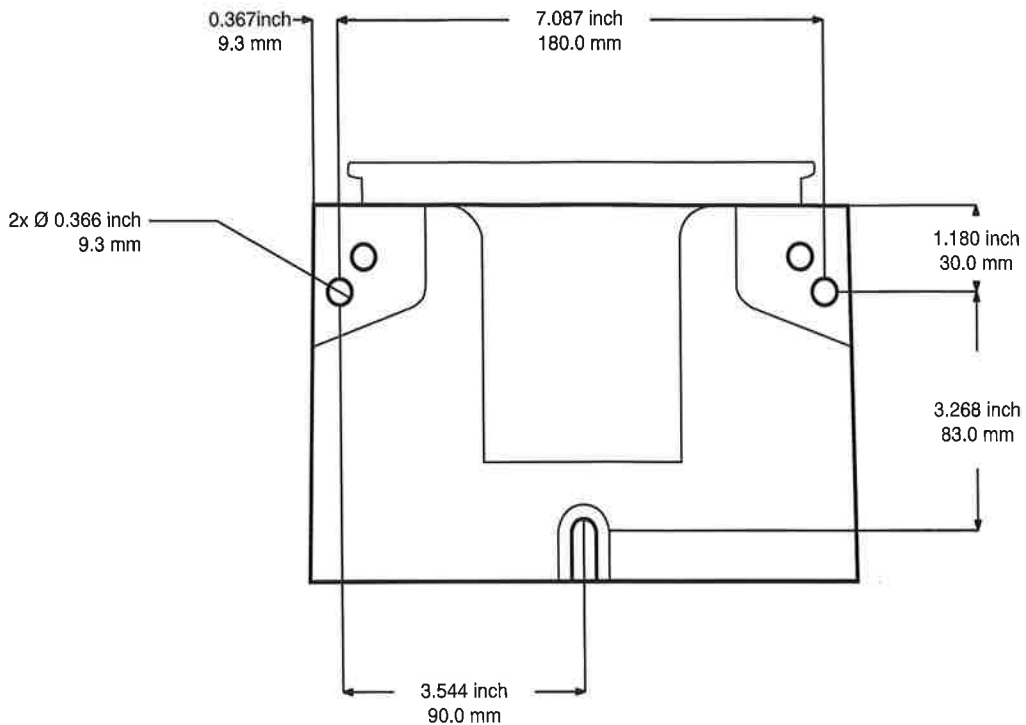

Option 2

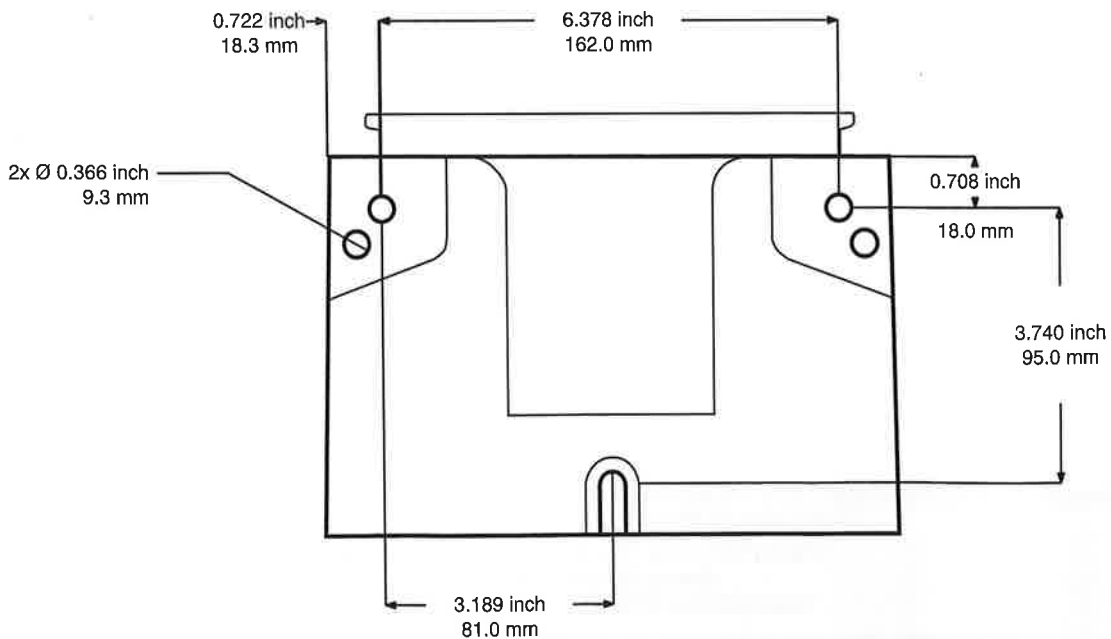

FIG. 52

Graco Standard Warranty

Graco warrants all equipment referenced in this document which is manufactured by Graco and bearing its name to be free from defects in material and workmanship on the date of sale to the original purchaser for use. With the exception of any special, extended, or limited warranty published by Graco, Graco will, for a period of twelve months from the date of sale, repair or replace any part of the equipment determined by Graco to be defective. This warranty applies only when the equipment is installed, operated and maintained in accordance with Graco's written recommendations.

This warranty does not cover, and Graco shall not be liable for general wear and tear, or any malfunction, damage or wear caused by faulty installation, misapplication, abrasion, corrosion, inadequate or improper maintenance, negligence, accident, tampering, or substitution of non-Graco component parts. Nor shall Graco be liable for malfunction, damage or wear caused by the incompatibility of Graco equipment with structures, accessories, equipment or materials not supplied by Graco, or the improper design, manufacture, installation, operation or maintenance of structures, accessories, equipment or materials not supplied by Graco.

This warranty is conditioned upon the prepaid return of the equipment claimed to be defective to an authorized Graco distributor for verification of the claimed defect. If the claimed defect is verified, Graco will repair or replace free of charge any defective parts. The equipment will be returned to the original purchaser transportation prepaid. If inspection of the equipment does not disclose any defect in material or workmanship, repairs will be made at a reasonable charge, which charges may include the costs of parts, labor, and transportation.

THIS WARRANTY IS EXCLUSIVE, AND IS IN LIEU OF ANY OTHER WARRANTIES, EXPRESS OR IMPLIED, INCLUDING BUT NOT LIMITED TO WARRANTY OF MERCHANTABILITY OR WARRANTY OF FITNESS FOR A PARTICULAR PURPOSE.

Graco's sole obligation and buyer's sole remedy for any breach of warranty shall be as set forth above. The buyer agrees that no other remedy (including, but not limited to, incidental or consequential damages for lost profits, lost sales, injury to person or property, or any other incidental or consequential loss) shall be available. Any action for breach of warranty must be brought within two (2) years of the date of sale.

GRACO MAKES NO WARRANTY, AND DISCLAIMS ALL IMPLIED WARRANTIES OF MERCHANTABILITY AND FITNESS FOR A PARTICULAR PURPOSE, IN CONNECTION WITH ACCESSORIES, EQUIPMENT, MATERIALS OR COMPONENTS SOLD BUT NOT MANUFACTURED BY GRACO. These items sold, but not manufactured by Graco (such as electric motors, switches, hose, etc.), are subject to the warranty, if any, of their manufacturer. Graco will provide purchaser with reasonable assistance in making any claim for breach of these warranties.

In no event will Graco be liable for indirect, incidental, special or consequential damages resulting from Graco supplying equipment hereunder, or the furnishing, performance, or use of any products or other goods sold hereto, whether due to a breach of contract, breach of warranty, the negligence of Graco, or otherwise.

FOR GRACO CANADA CUSTOMERS

The Parties acknowledge that they have required that the present document, as well as all documents, notices and legal proceedings entered into, given or instituted pursuant hereto or relating directly or indirectly hereto, be drawn up in English. Les parties reconnaissent avoir convenu que la rédaction du présente document sera en Anglais, ainsi que tous documents, avis et procédures judiciaires exécutés, donnés ou intentés, à la suite de ou en rapport, directement ou indirectement, avec les procédures concernées.

Graco Information

For the latest information about Graco products, visit www.graco.com.

TO PLACE AN ORDER, contact your Graco distributor or call to identify the nearest distributor.

Phone: 612-623-6928 **or Toll Free:** 1-800-533-9655, **Fax:** 612-378-3590

All written and visual data contained in this document reflects the latest product information available at the time of publication. Graco reserves the right to make changes at any time without notice.

Original instructions. This manual contains English. MM 332305

Graco Headquarters: Minneapolis

International Offices: Belgium, China, Japan, Korea

GRACO INC. AND SUBSIDIARIES • P.O. BOX 1441 • MINNEAPOLIS MN 55440-1441 • USA

Copyright 2013, Graco Inc. All Graco manufacturing locations are registered to ISO 9001.

www.graco.com

August 2017